

- Gantry type
- Cable carrier
- Z-axis: clamped base / moving table type (200W)

Ordering method

MXYx - C							R			BB			
Model	Cable	Combination	X-axis stroke	Y-axis stroke	ZR-axis	Z-axis stroke	Cable length	Controller	Usable for CE	Regenerative unit	Option I/O	Network option	Battery
G1 G2 G3 G4			25 to 125cm	15 to 85cm	ZFL20 ZFL10	15 to 35cm	3L: 3.5m (Standard) 5L: 5m 10L: 10m	RXC240	No entry: Standard E: CE marking	R: RGU-2	N: P: Standard I/O 16/8 N1, P1: 40/24 N2, P2: 64/40 N3, P3: 88/56 N4, P4: 112/72	No entry: None CC: CC-Link DN: DeviceNet PB: Profibus EN: Ethernet YC: YC-Link	BB: 4 pcs

Note 1. N to N4 if NPN was selected, or P to P4 if PNP was selected for the I/O board.
Note 2. Available only for the master.

Specification

	X-axis	Y-axis	Z-axis: ZFL20	Z-axis: ZFL10
Axis construction ^{Note 1}	F17	F14H-BK	F10 equivalent guide-reinforced model	
AC servo motor output (W)	400	200	200	
Repeatability ^{Note 2} (mm)	+/-0.01	+/-0.01	+/-0.01	
Drive system	Ball screw (Class C7)	Ball screw (Class C7)	Ball screw (Class C7)	
Ball screw lead (Deceleration ratio) (mm)	20	20	20	10
Maximum speed ^{Note 3} (mm/sec)	1200	1200	1200	600
Moving range (mm)	250 to 1250	150 to 850	150 to 350	
Robot cable length (m)	Standard: 3.5 Option: 5, 10			

Note. The standard types are ZFL with higher rigidity as compared with ZF types which are conventional standard types. When you need the ZF type, please consult YAMAHA.
Note 1. Use caution that the flame machining (installation holes, tap holes) differs from single-axis robots.
Note 2. Positioning repeatability in one direction.
Note 3. When the X-axis stroke is longer than 850mm (750mm for Y-axis), resonance of the ball screw may occur depending on the operation conditions (critical speed). In this case, reduce the speed setting on the program by referring to the maximum speeds shown in the table below.

Maximum payload (kg)

Y stroke (mm)	Z stroke (mm)					
	ZFL20			ZFL10		
150	8	8	8	15	15	15
250	8	8	8	15	15	15
350	8	8	8	15	15	15
450	8	8	8	15	15	15
550	8	8	8	15	15	15
650	8	8	8	15	15	15
750	8	8	8	15	15	15
850	8	8	8	12	11	10

Controller

Controller	Operation method
RXC240-R	Programming / I/O point trace / Remote command / Operation using RS-232C communication

MXYx 3 axes / ZFL20/10 (G1)

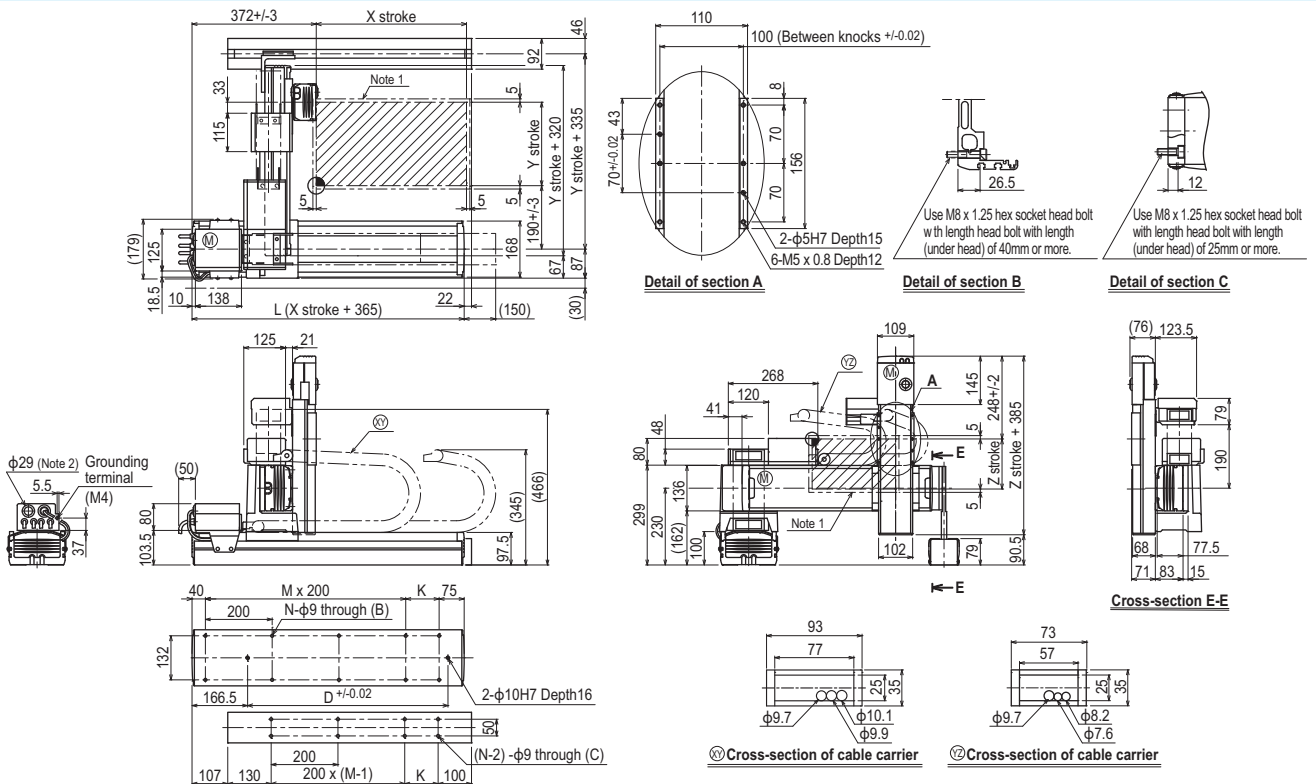

	X stroke	250	350	450	550	650	750	850	950	1050	1150	1250
L		615	715	815	915	1015	1115	1215	1315	1415	1515	1615
K		100	200	100	200	100	200	100	200	100	200	100
D		240	420	600	600	780	780	960	960	1140	1140	1320
M		2	2	3	3	4	4	5	5	6	6	7
N		8	8	10	10	12	12	14	14	16	16	18
Y stroke		150	250	350	450	550	650	750	850			
Z stroke		150	250	350								
Maximum speed for each stroke (mm/sec) ^{Note 3}	X-axis	1200										
	Speed setting	-										
	Y-axis	1200										
	Speed setting	-										

Note 1. The moving range when returning to origin and the stop position when stopping by the mechanical stopper.
Note 2. User cable extraction port.

Note 3. When the X-axis stroke is longer than 850mm (750mm for Y-axis), resonance of the ball screw may occur depending on the operation conditions (critical speed). In this case, reduce the speed setting on the program by referring to the maximum speeds shown in the table at the left.

APPLICATION
Compact
single-axis robots
TRANSERO
Single-axis robots
FLIP-X
Linear motor
single-axis robots
PHASER
Cartesian
robots
XX-X
SCARA
robots
YK-XG
Pick & place
robots
YP-X
CLEAN
CONTROLLER
INFORMATION
Arm type
Gantry type
Moving arm
type
Pole type
XZ type