

HXYx 2 axes / ZH

XY type Cable carrier

Ordering method

HXYx - C			ZH			RCX222		R			
Model	Cable	Combination	X-axis stroke	ZR-axis	Z-axis stroke	Cable length	Controller	Usable for CE	Regenerative unit	Input/Output selection 1	Input/Output selection 2
F1		F1	25 to 125cm		25 to 55cm	3L: 3.5m (Standard) 5L: 5m 10L: 10m	RCX222 DRCX2010	No entry: Standard E: CE marking	R: RG2 (RCX222) R: RGU-2 (DRCX)	N: NPN ^{Note 1} P: PNP CC: CC-Link DN: DeviceNet PB: Profibus EN: Ethernet ^{Note 1} YC: YC-Link ^{Note 2}	No entry: None N1: OP.DIO24/16 (NPN) ^{Note 1} P1: OP.DIO24/17 (PNP) EN: Ethernet ^{Note 1} No E, S

Note 1. NPN and Ethernet cannot be selected if using CE marking.
 Note 2. Available only for the master.
 Note 3. Only when CC or DN or PB was selected for I/O select 1 above. EN can be selected in I/O select 2.

Specification

	X-axis	Z-axis
Axis construction ^{Note 1}	F17	F14H-BK
AC servo motor output (W)	400	200
Repeatability ^{Note 2} (mm)	+/-0.01	+/-0.01
Drive system	Ball screw (Class C7)	Ball screw (Class C7)
Ball screw lead (Deceleration ratio) (mm)	20	5
Maximum speed ^{Note 3} (mm/sec)	1200	300
Moving range (mm)	250 to 1250	250 to 550
Robot cable length (m)	Standard: 3.5 Option: 5,10	

Note 1. Use caution that the flange machining (installation holes, tap holes) differs from single-axis robots.
 Note 2. Positioning repeatability in one direction.
 Note 3. When the X-axis stroke is longer than 850mm, resonance of the ball screw may occur depending on the operation conditions (critical speed). In this case, reduce the speed setting on the program by referring to the maximum speeds shown in the table below.

Maximum payload (kg)

X stroke (mm)	Z stroke (mm)
250 to 1250	250 to 550
	30

Controller

Controller	Operation method
RCX222-R	Programming / I/O point trace / Remote command / Operation using RS-232C communication
DRCX2010-R	

HXYx 2 axes / ZH F1

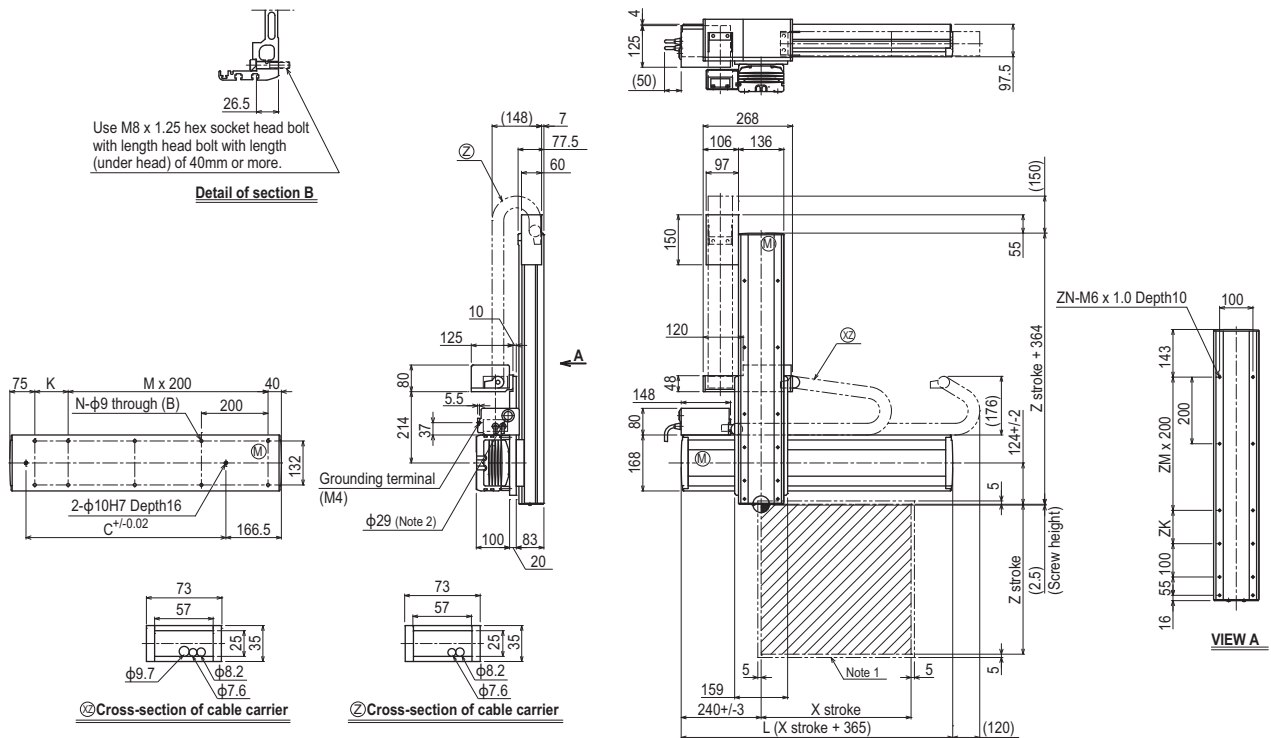

X stroke	250	350	450	550	650	750	850	950	1050	1150	1250
L	615	715	815	915	1015	1115	1215	1315	1415	1515	1615
K	100	200	100	200	100	200	100	200	100	200	100
C	240	420	600	600	780	780	960	960	1140	1140	1320
M	2	2	3	3	4	4	5	5	6	6	7
N	8	8	10	10	12	12	14	14	16	16	18
Z stroke	250	350	450	550							
ZK	100	200	100	200							
ZM	1	1	2	2							
ZN	10	10	12	12							

Note 1. The moving range when returning to origin and the stop position when stopping by the mechanical stopper.
 Note 2. User cable extraction port.

Maximum speed for each stroke (mm/sec) ^{Note 3}	X-axis	1200	960	840	720	600	480
Speed setting		-	80%	70%	60%	50%	40%

Note 3. When the X-axis stroke is longer than 850mm, resonance of the ball screw may occur depending on the operation conditions (critical speed). In this case, reduce the speed setting on the program by referring to the maximum speeds shown in the table at the left.

APPLICATION
 TRANSERO
 FLIP-X
 PHASER
 XY-X
 YK-XG
 YP-X
 CLEAN
 CONTROLLER
 INFORMATION
 Arm type
 Gantry type
 Moving arm type
 Pole type
 XZ type