

# SR03 Rod type

- CE compliance
- Origin on the non-motor side is selectable



## Ordering method

### SR03

<b>Model</b>	<b>Lead</b>	<b>Model</b>	<b>Brake</b>	<b>Origin position</b>	<b>Bracket plate</b>	<b>Stroke</b>	<b>Cable length</b> <sup>Note 3</sup>
	12: 12mm 06: 6mm	S: Straight model R: Space-saving model <sup>Note 1</sup> (motor installed on right) L: Space-saving model <sup>Note 1</sup> (motor installed on left) U: Space-saving model <sup>Note 1</sup> (motor installed on top)	N: With no brake B: With brake	N: Standard <sup>Note 2</sup> Z: Non-motor side	N: No plate H: With plate V: With flange	50 to 200 (50mm pitch)	1K: 1m 3K: 3m 5K: 5m 10K: 10m

Note 1. See P.129 for grease gun nozzles.  
Note 2. If changing from the origin position at the time of purchase, the machine reference amount must be reset. For details, refer to the manual.

Note 3. The robot cable is flexible and resists bending.  
Note 4. See P.498 for DIN rail mounting bracket.  
Note 5. Select this selection when using the gateway function. For details, see P.60.

<b>S2</b>	<b>SH</b>	<b>SD</b>
<b>Robot positioner</b>	<b>Robot positioner</b>	<b>Robot driver</b>
S2: TS-S2 <sup>Note 4</sup>	SH: TS-SH	SD: TS-SD
<b>I/O</b>	<b>I/O</b>	<b>I/O cable</b>
NP: NPN PN: PNP CC: CC-Link DN: DeviceNet™ EP: EtherNet/IP™ PT: PROFINET GW: No I/O board <sup>Note 5</sup>	NP: NPN PN: PNP CC: CC-Link DN: DeviceNet™ EP: EtherNet/IP™ PT: PROFINET GW: No I/O board <sup>Note 5</sup>	t: 1m
	<b>Battery</b>	
	B: With battery (Absolute) N: None (Incremental)	

## Basic specifications

<b>Motor</b>	42 □ Step motor
<b>Resolution (Pulse/rotation)</b>	20480
<b>Repeatability (mm)</b>	+/-0.02
<b>Deceleration mechanism</b>	Ball screw φ8 (Class C10)
<b>Ball screw lead (mm)</b>	12
<b>Maximum speed</b> <sup>Note 1</sup> (mm/sec)	500      250
<b>Maximum payload (kg)</b>	<b>Horizontal</b> <b>Vertical</b>
	10      20
	4      8
<b>Max. pressing force (N)</b>	75      100
<b>Stroke (mm)</b>	50 to 200 (50pitch)
<b>Lost motion</b>	0.1mm or less
<b>Rotating backlash (°)</b>	+/-1.0
<b>Overall length (mm)</b>	<b>Horizontal</b> <b>Vertical</b>
	Stroke+236.5      Stroke+276.5
<b>Maximum outside dimension of body cross-section (mm)</b>	W48 × H56.5
<b>Cable length (m)</b>	Standard: 1 / Option: 3, 5, 10

Note 1. The maximum speed needs to be changed in accordance with the payload.  
See the "Speed vs. payload" graph shown on the right.  
For details, see P. 128.

## Speed vs. payload

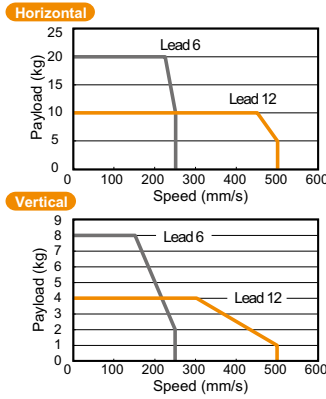

## Running life

5000 km on models other than shown below.  
Running life of only the model shown below becomes shorter than 5000 km depending on the payload, so check the running life curve.

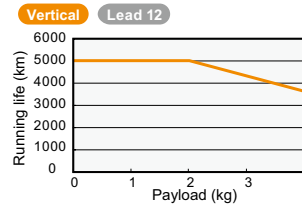

Note. See P.129 for running life distance to life time conversion example.

## Motor installation (Space-saving model)

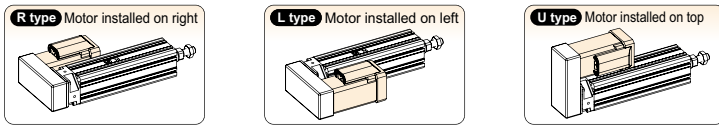

## Controller

Controller	Operation method	Controller	Operation method
TS-S2	I/O point trace / Remote command	TS-SD	Pulse train control
TS-SH			

## SR03 Straight model S

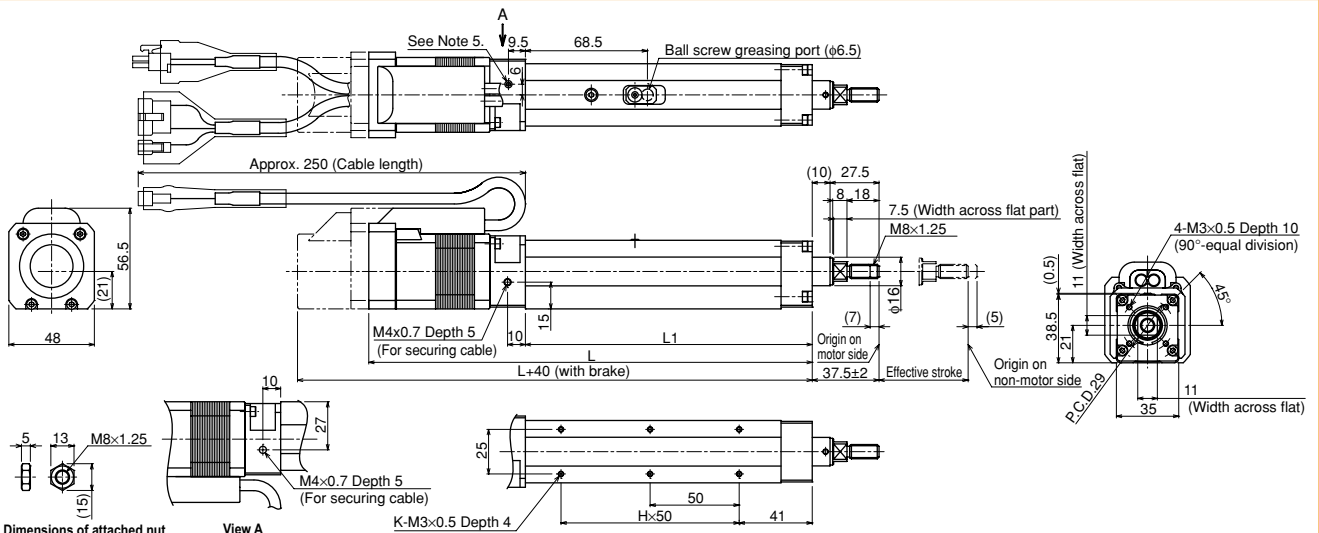

**Option: Horizontal installation plate (foot)**

\* Contents of option: Plate, 2 pcs.  
See our robot manuals for additional settings.

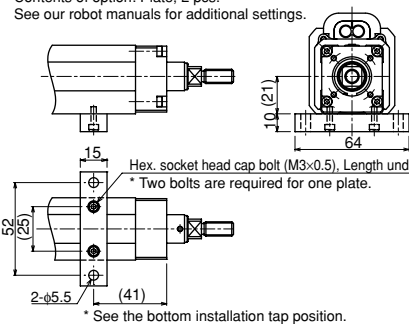

**Option: Vertical installation plate (flange)**

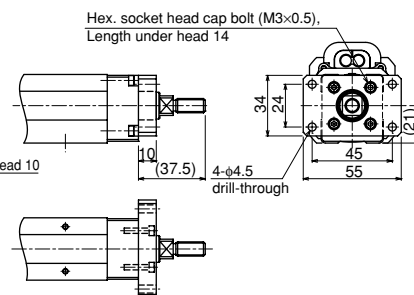

Effective stroke	50	100	150	200
L1	161	211	261	311
L	249	299	349	399
H	2	3	4	5
K	6	8	10	12
<b>Weight (kg)</b> <sup>Note 7</sup>	1.1	1.3	1.4	1.6

Note 1. It is possible to apply only the axial load.  
Use the external guide together so that any radial load is not applied to the rod.  
Note 2. The orientation of the width across flat part is undefined to the base surface.  
Note 3. Use the support guide together to maintain the straightness.  
Note 4. When running the cables, secure cables so that any load is not applied to them.  
Note 5. Remove the M4 hex. socket head cap set bolts and use them to secure the cables. (Effective screw thread depth 5)  
Note 6. The cable's minimum bend radius is R30.  
Note 7. Models with a brake will be 0.2kg heavier.  
Note 8. Distance to mechanical stopper.

## SR03 Space-saving model (motor installed on right) **R**

**Dimensions of attached nut**

Effective stroke	50	100	150	200
L1	161	211	261	311
L	204	254	304	354
H	2	3	4	5
K	6	8	10	12
Weight (kg) <sup>Note 7</sup>	1.3	1.5	1.6	1.8

**Option: Horizontal installation plate (foot)**

\* Contents of option: Plate, 2 pcs.  
See our robot manuals for additional settings.

Hex. socket head cap bolt (M3×0.5), Length under head 10  
\* Two bolts are required for one plate.

**Option: Vertical installation plate (flange)**

Hex. socket head cap bolt (M3×0.5), Length under head 14

**Note 1.** It is possible to apply only the axial load. Use the external guide together so that any radial load is not applied to the rod.  
**Note 2.** The orientation of the width across flat part is undefined to the base surface.  
**Note 3.** Use the support guide together to maintain the straightness.  
**Note 4.** When running the cables, secure cables so that any load is not applied to them.  
**Note 5.** Remove the M4 hex. socket head cap set bolts and use them to secure the cables. (Effective screw thread depth 5)  
**Note 6.** The cable's minimum bend radius is R30.  
**Note 7.** Models with a brake will be 0.2kg heavier.  
**Note 8.** Distance to mechanical stopper.

## SR03 Space-saving model (motor installed on left) **L**

**Dimensions of attached nut**

Effective stroke	50	100	150	200
L1	161	211	261	311
L	204	254	304	354
H	2	3	4	5
K	6	8	10	12
Weight (kg) <sup>Note 7</sup>	1.3	1.5	1.6	1.8

**Option: Horizontal installation plate (foot)**

\* Contents of option: Plate, 2 pcs.  
See our robot manuals for additional settings.

Hex. socket head cap bolt (M3×0.5), Length under head 10  
\* Two bolts are required for one plate.

**Option: Vertical installation plate (flange)**

Hex. socket head cap bolt (M3×0.5), Length under head 14

**Note 1.** It is possible to apply only the axial load. Use the external guide together so that any radial load is not applied to the rod.  
**Note 2.** The orientation of the width across flat part is undefined to the base surface.  
**Note 3.** Use the support guide together to maintain the straightness.  
**Note 4.** When running the cables, secure cables so that any load is not applied to them.  
**Note 5.** Remove the M4 hex. socket head cap set bolts and use them to secure the cables. (Effective screw thread depth 5)  
**Note 6.** The cable's minimum bend radius is R30.  
**Note 7.** Models with a brake will be 0.2kg heavier.  
**Note 8.** Distance to mechanical stopper.

SR03 Space-saving model (motor installed on top) U

**Option: Horizontal installation plate (foot)**

\* Contents of option: Plate, 2 pcs.  
See our robot manuals for additional settings.

**Option: Vertical installation plate (flange)**

Hex. socket head cap bolt (M3×0.5), Length under head 10  
\* Two bolts are required for one plate.

Hex. socket head cap bolt (M3×0.5), Length under head 14

**Dimensions of attached nut**

Effective stroke	50	100	150	200
L1	161	211	261	311
L	204	254	304	354
H	2	3	4	5
K	6	8	10	12
<b>Weight (kg)</b> <sup>Note 7</sup>	1.3	1.5	1.6	1.8

Note 1. It is possible to apply only the axial load.  
Use the external guide together so that any radial load is not applied to the rod.  
Note 2. The orientation of the width across flat part is undefined to the base surface.  
Note 3. Use the support guide together to maintain the straightness.  
Note 4. When running the cables, secure cables so that any load is not applied to them.  
Note 5. Remove the M4 hex. socket head cap set bolts and use them to secure the cables.  
(Effective screw thread depth 5)  
Note 6. The cable's minimum bend radius is R30.  
Note 7. Models with a brake will be 0.2kg heavier.  
Note 8. Distance to mechanical stopper.