

TL18

series



Product Segments

- **Care Motion**
- **Comfort Motion**
- **Ergo Motion**
- **Industrial Motion**

TiMOTION's TL18 column is designed for medical applications such as nurse carts, ophthalmological devices, X-ray machines, etc. The TL18 features an extruded aluminum rectangular appearance. Our high capacity, yet economical, TL18 provides stable vertical lifting. This streamlines the engineering design process and replaces the older style, unsafe lifting mechanisms which have many moving stages and pinch points.

General Features

Maximum load & self- locking force	4,500N in push
Maximum dynamic bending moment	250Nm
Maximum static bending moment	500Nm
Maximum speed at full load	28mm/s (with 500N in a push condition)
Minimum installation dimension	≥ Stroke+147mm
Stroke	100~700mm
Operational temperature range	+5°C~+45°C
Options	Hall sensor(s), cable exit from top/ bottom side, direct cut system
Certificate	IEC60601-1, ES60601-1, IEC60601-1-2, UL73, EMC

Drawing

Standard Dimensions
(mm)

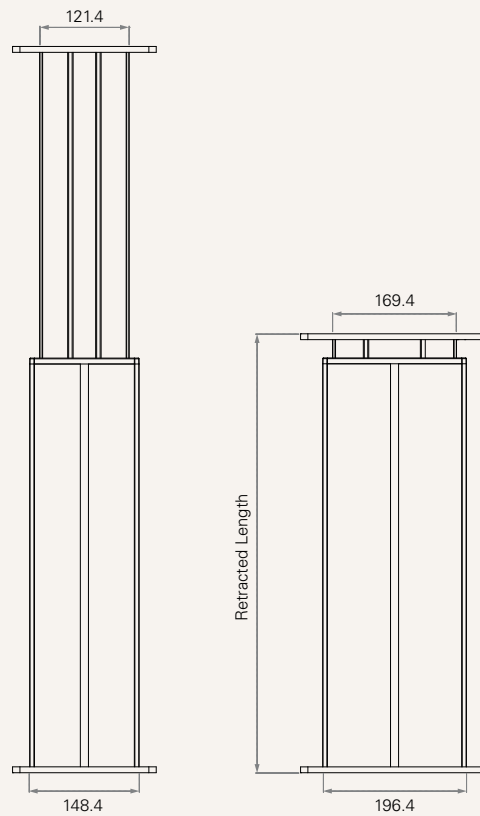

Load and Speed

CODE	Load (N)	Bending Moment- X direction		Self Locking Force (N)	Typical Current (A)		Typical Speed (mm/s)	
	Push	Dynamic	Static		No Load 24V DC	With Load 24V DC	No Load 24V DC	With Load 24V DC
Motor Speed (3800RPM)								
U	4500	250	500	4500	2.5	4.9	11.4	6.6
Z	3000	250	500	3000	2.5	5.5	17.1	9.5
W	2000	250	500	2000	2.5	4.8	22.9	13.1
S	1500	250	500	1500	2.5	4.7	30.0	18.9
V	500	250	500	500	2.5	4.0	45.0	28.0

Note

- 1 The current & speed in table are tested with 24V DC motor. With a 12V DC motor, the current is approximately twice the current measured in 24V DC; speed will be similar for both voltages.
- 2 The current & speed in table and diagram are tested with TiMOTION control boxes, and there will be around 10% tolerance depending on different models of the control box.
(Under no load condition, the voltage is around 32V DC. At rated load, the voltage output will be around 24V DC)
- 3 Bending Momen: Y direction= X*0.8

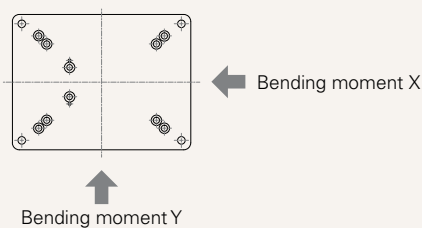

Performance Data (24V DC Motor)

Motor Speed (3800RPM)

Speed vs. Load

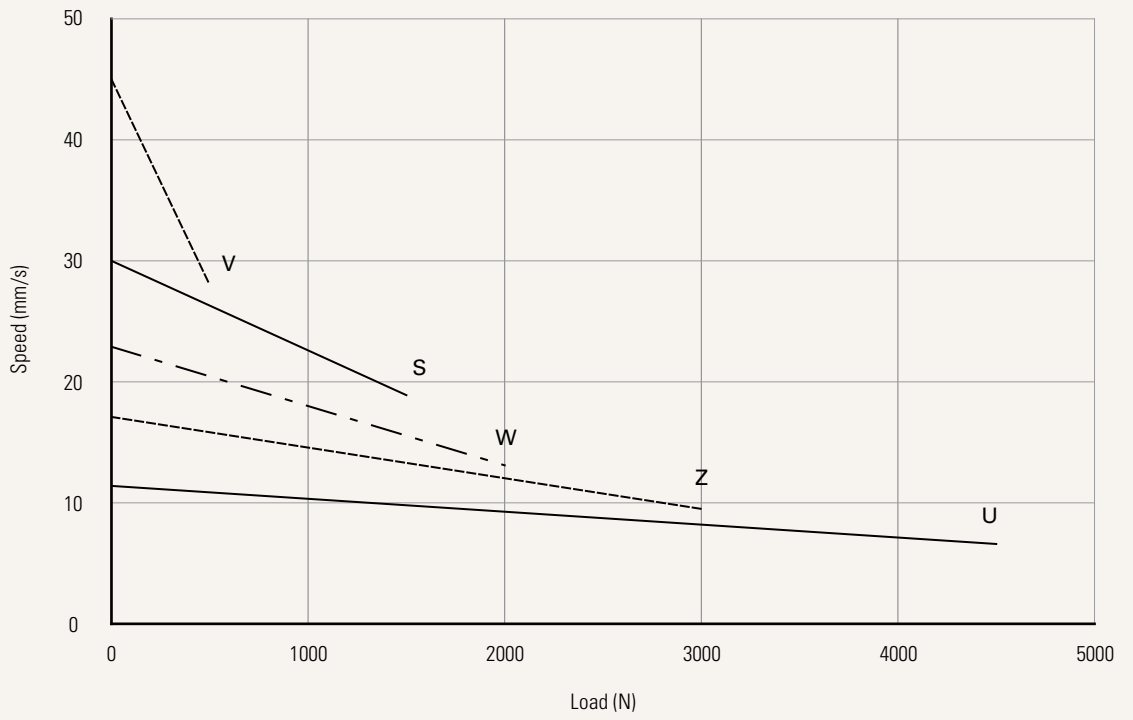

Current vs. Load

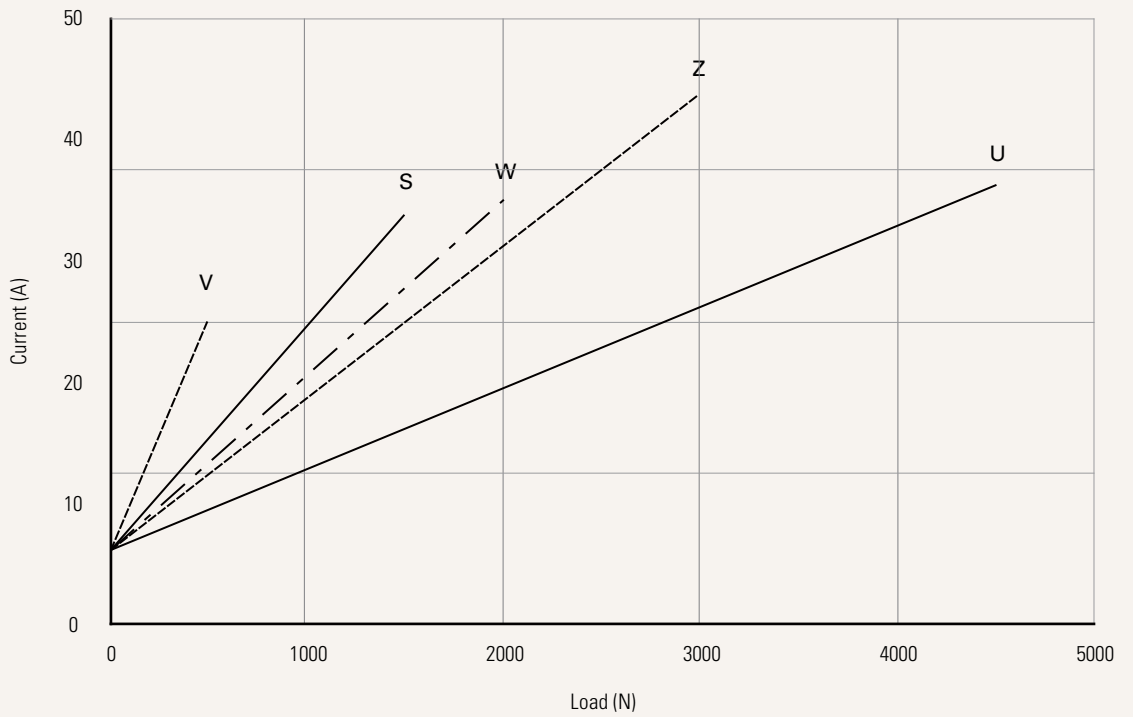

Voltage	1 = 12V DC	2 = 24V DC	
Load and Speed	See page 2		
Stroke (mm)	100-700		
Retracted Length (mm)	See page 2		
Cable Exit	2 = Bottom side cable	3 = Top side cable	
Special Functions for Spindle Sub-Assembly	0 = Without (standard)	1 = Safety nut	
Functions for Limit Switches	1 = Two switches at full retracted / extended positions to cut current 2 = Two switches at full retracted / extended positions to send signal		
Color	1 = Black	2 = Matte silver	
IP Rating	1 = Without		
Output Signals	0 = Without	2 = Hall sensor*2	
Top Plate	1 = Small plate	2 = Big plate	
Bottom Plate	1 = Small plate	2 = Big plate	
Connector	1 = DIN 6P, 90° plug C = Y cable, for direct cut system	E = Molex 8P, plug	
Cable Length (mm)	1 = Straight, 500 2 = Straight, 750 3 = Straight, 1000	4 = Straight, 1250 5 = Straight, 1500 6 = Straight, 1750	7 = Straight, 2000 B = For direct cut system See page 6

Note

¹ The TL18 is designed especially for push applications, not suitable for pull applications.

Retracted Length (mm)

1. Retracted length needs to \geq Stroke+A

A. Plate

Top plate	Bottom plate	
	1	2
1	+147	+151
2	+151	+155

Cable Exit

2 = Bottom side cable

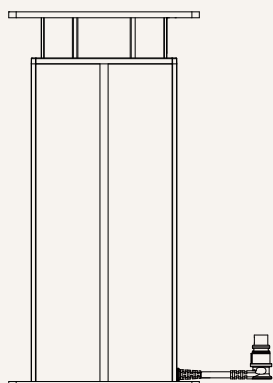

2 = Bottom side cable
Y cable, for TH + TP

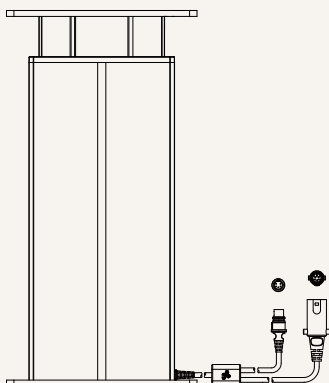

3 = Top side cable

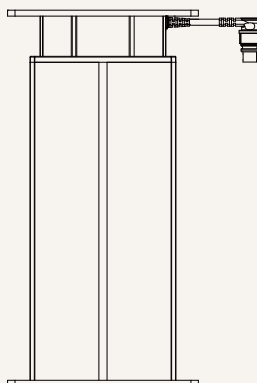

3 = Top side cable
Y cable, for TH + TP

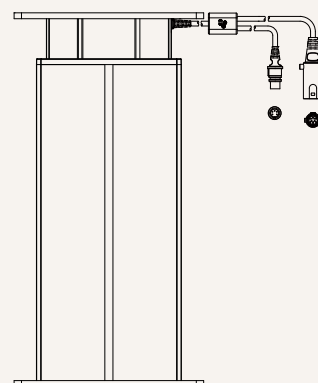

Functions for Limit Switches

Wire Definitions

CODE	Pin	1 (Green)	2 (Red)	3 (White)	4 (Black)	5 (Yellow)	6 (Blue)
1	extend (VDC+)	N/A	N/A	N/A	N/A	retract (VDC+)	N/A
2	extend (VDC+)	N/A	N/A	middle switch pin B	middle switch pin A	retract (VDC+)	N/A

Connector

1 = DIN 6P, 90° plug

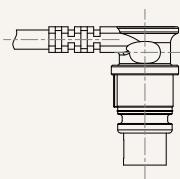

E= Molex 8P, plug

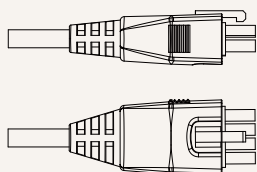

C= Y cable, for direct cut system

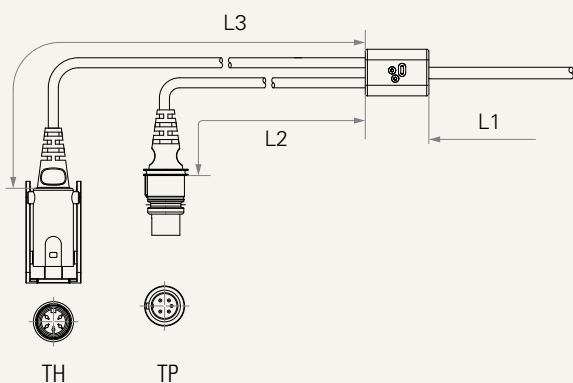

Cable length for direct cut system (mm)

CODE	L1	L2	L3
H	100	100	100

Top Plate

1 = Small plate

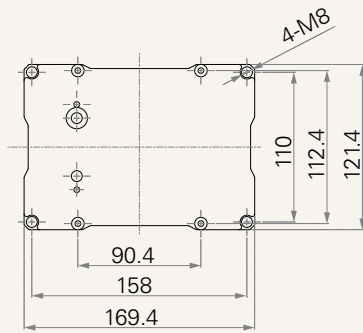

Small Plate: 4 fixation holes
Thickness 4mm

2 = Big plate

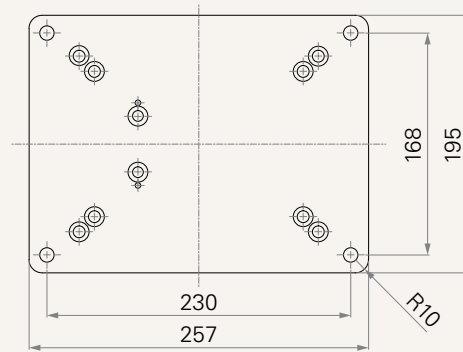

Big Plate: 4 fixation holes
Thickness 8mm

Bottom Plate

1 = Small plate

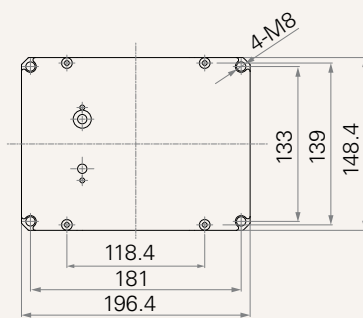

Small Plate: 4 fixation holes
Thickness 4mm

2 = Big plate

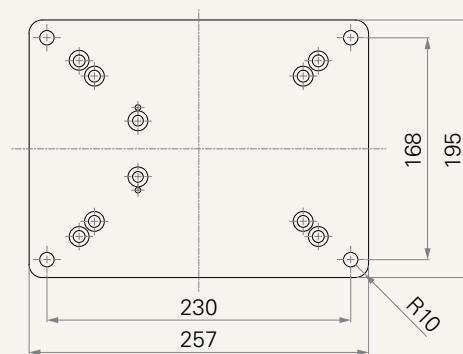

Big Plate: 4 fixation holes
Thickness 8mm

Terms of Use

The user is responsible for determining the suitability of TiMOTION products for a specific application. TiMOTION products are subject to change without prior notice.