

THK

NEW

4-Way Equal Load Roller-Type LM Guide

HRX

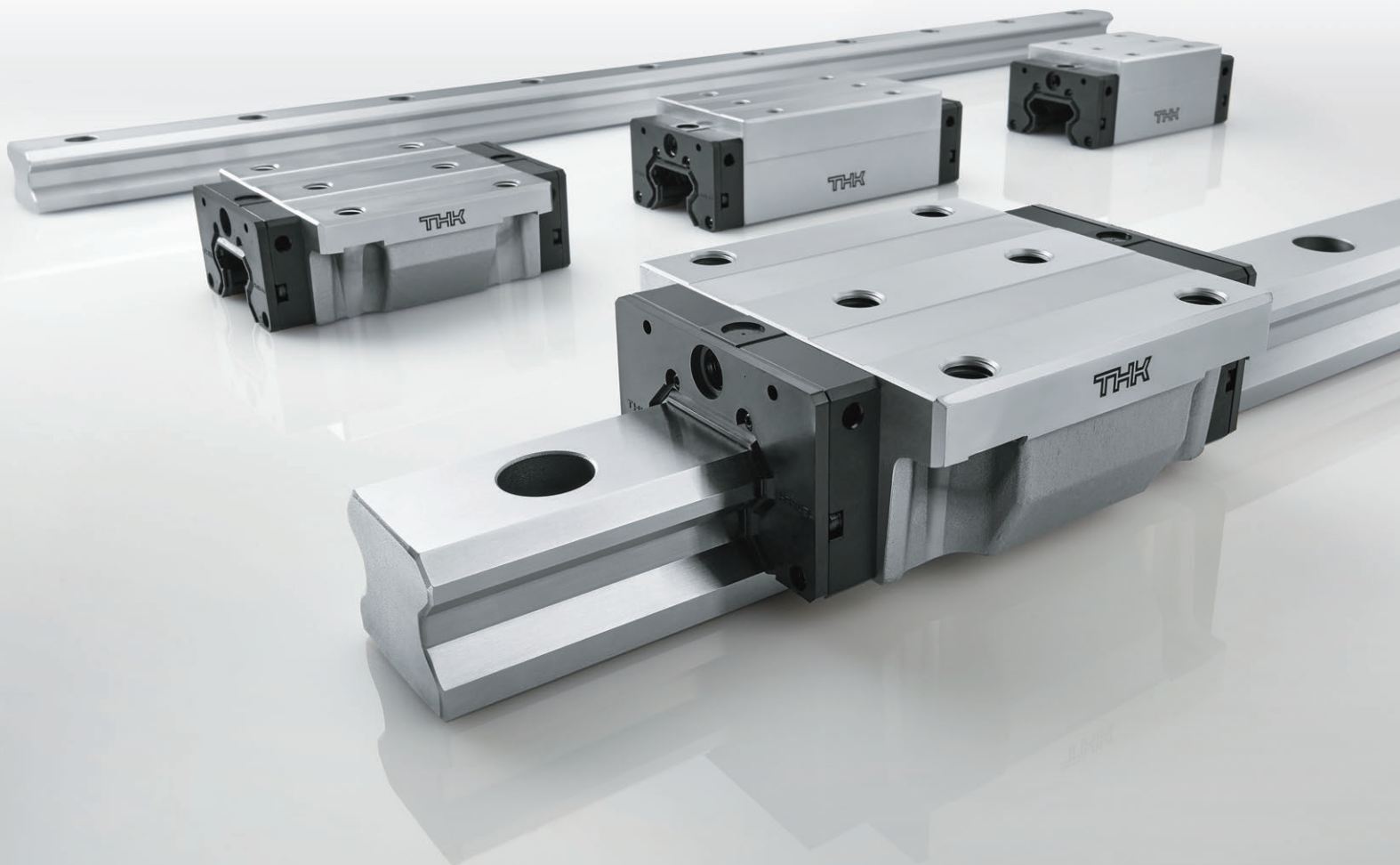

LM Guide suitable for ultra-high rigidity and ultra heavy loads



Model HRX

Roller Type LM Guide

LM Guide suitable for ultra-high rigidity and ultra-heavy loads

Feature 1 Ultra-High Rigidity and Ultra-Heavy Loads p. 3

The HRX is an LM Guide that uses rollers as a rolling element for higher rigidity. Also, compared to our existing roller products, we have extended the overall length of the LM block and increased the number of load-bearing rollers to achieve improved static load rating.

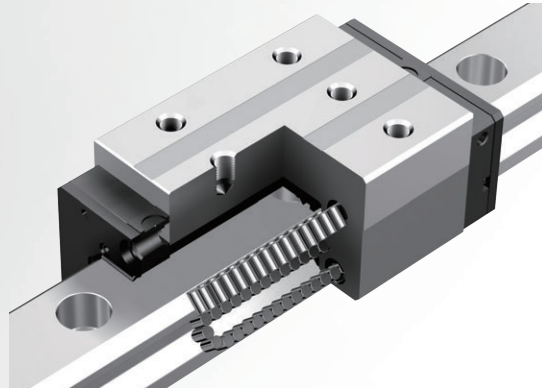

Internal structure of the HRX

Feature 2 4-Way Equal Load p. 3

On the HRX, each row of rollers is arranged at a contact angle of 45° so that the LM block receives an equal load rating in all directions (radial, reverse radial, and horizontal directions), ensuring high rigidity in all directions.

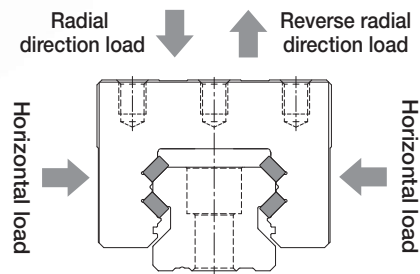

Feature 3 LM Blocks and LM Rails Available for Individual Sale p. 15

The HRX lineup features interchangeable products that can meet specifications by freely combining LM blocks and LM rails of the same model number. See p. 15 for details.

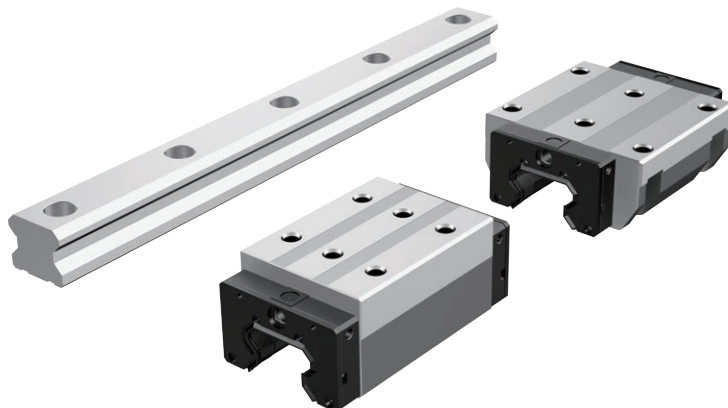

Roller Type LM Guide Model HRX

Feature 1 Ultra-high rigidity and ultra heavy loads

For the HRX, in order to achieve an improved basic static load rating, we have extended the overall length of the LM block and increased the number of load-bearing rollers.

LM block overall length and basic static load rating

Model No.		Overall block length L_1		Basic static load rating C_0	
		Our existing roller products	HRX	Our existing roller products	HRX
#35	C/R	82.2	92.2	119	150.1
	LC/LR	112.2	120.2	165	195.7
#45	C/R	107	115.7	192	250.4
	LC/LR	142	150.7	256	326.7
#55	C/R	129.2	143.7	266	369.9
	LC/LR	179.2	192.7	366	497.9
#65	C/R	171.7	195.7	441	567
	LC/LR	229.8	260.7	599	756

Feature 2 4-Way Equal Load

The Model HRX is designed to have an equal basic load rating on the LM block for all four directions.

(*Four directions: radial, reverse radial, left, and right)

As a result, this model can be used in any orientation, enabling a wide variety of applications.

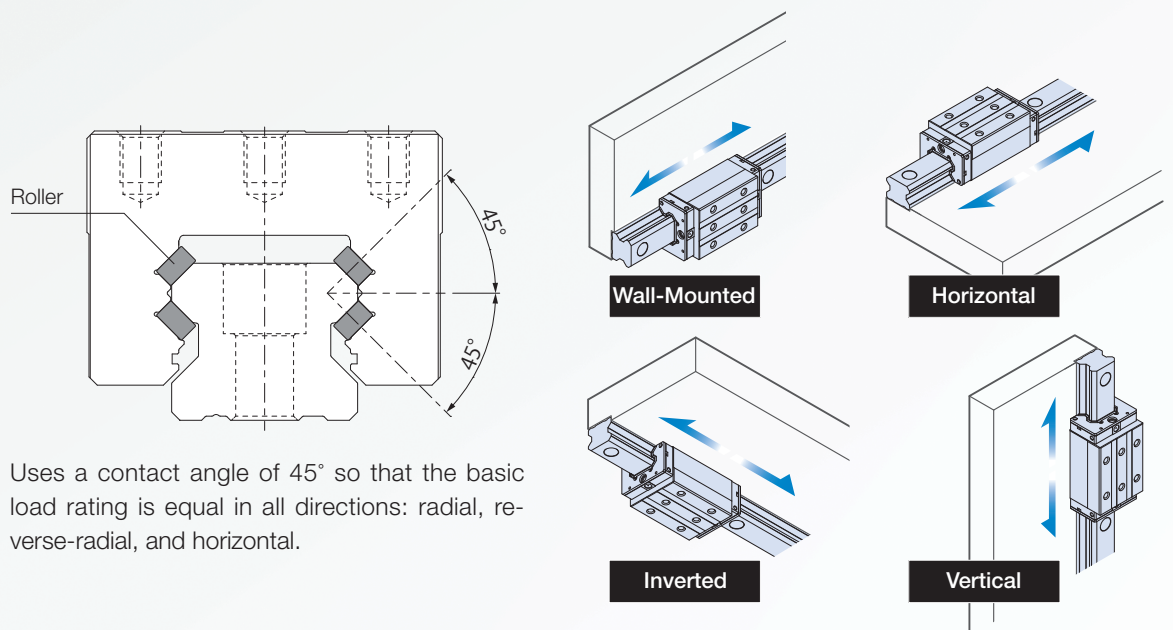

Uses a contact angle of 45° so that the basic load rating is equal in all directions: radial, reverse-radial, and horizontal.

This model is equally suited for use in a horizontal orientation and any other orientation.

Structure of the HRX

The Model HRX features raceways on the sides of the LM rail, which come into contact with the rollers at a 45° angle.

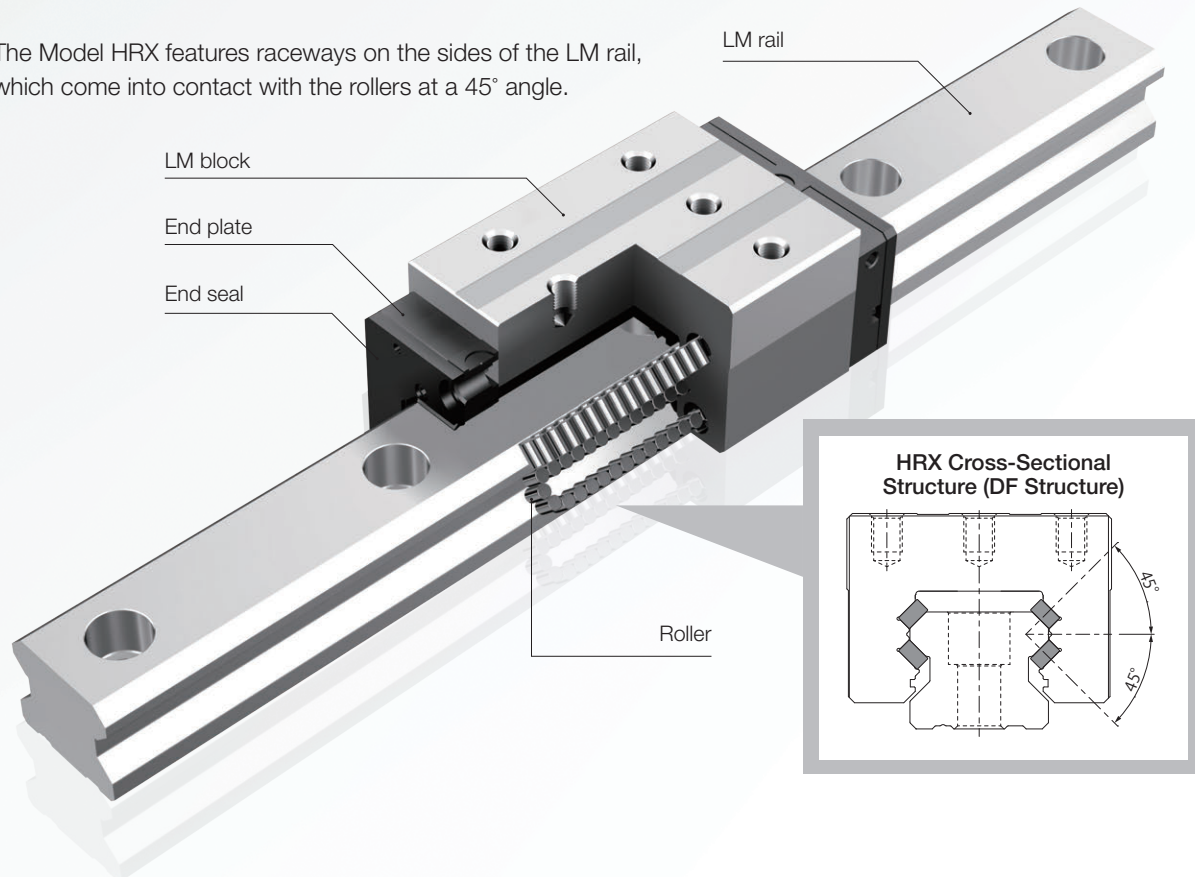

Lineup

The Model HRX comes in four sizes ranging from 35 to 65, and a lineup of four block types is available: C/LC, and R/LR. The Model HRX's dimensions conform to world-standard ISO specifications (ISO 12090-1:2011 Rolling Bearings).

Only #65R/LR height M differs from ISO dimensions.

Lineup

Block Type	HRX35	HRX45	HRX55	HRX65
Standard type	R	○	○	○
	C	○	○	○
Long type	LR	○	○	○
	LC	○	○	○

HRX-C/LC

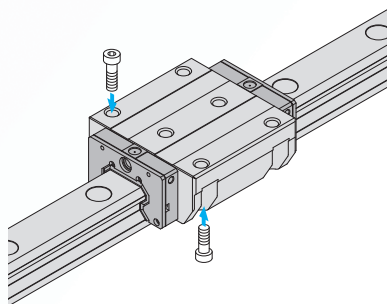

The flange of this LM block has tapped holes. This type can be mounted from the top or the bottom.

HRX-R/LR

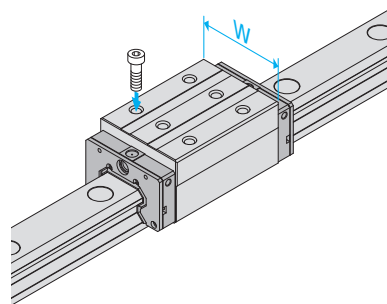

With this type, the LM block has a smaller width (W) and tapped holes. It is ideal for compact designs.

Contamination Protection Accessories

It is necessary to prevent foreign materials from getting inside the product, as it will lead to abnormal wear and a shortened service life. If it is likely that foreign materials will get inside, it is important to select an effective sealing or contamination protection device suited to the environmental conditions.

Seals

End seals made of a synthetic rubber that are highly resistant to wear and side seals that further improve dust-proofing effectiveness are available. Use the symbols in the table to the right to specify if you need a contamination protection accessory.

Symbol	Contamination protection accessories
UU	End seals
SS	End seals + side seals + inner seals
DD	Double seals + side seals + inner seals
ZZ	End seals + side seals + inner seals + metal scrapers
KK	Double seals + side seals + inner seals + metal scrapers

End Seal

Used in locations exposed to dust

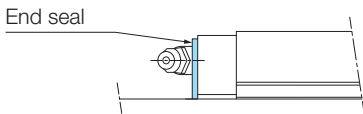

Side Seal

Used in locations where dust may enter the LM block from the side or bottom surfaces, such as vertical, horizontal, and inverted configurations

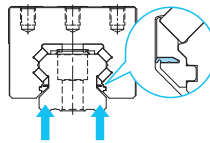

Inner Seal

Used in locations severely exposed to dust or cutting chips

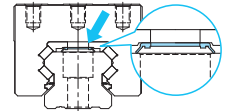

Double Seals

Used in locations exposed to dust

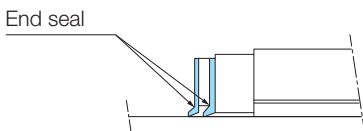

Metal Scraper (Non-Contact)

Used in locations where welding spatter may adhere to the LM rail

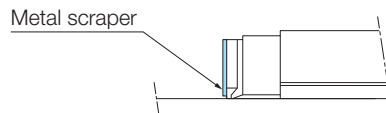

Seal Resistance Value

See the table below for the maximum seal resistance of SS seals per LM block when the product is lubricated.

Unit: N

Model No.	Seal symbol	Maximum Seal Resistance
HRX35	SS	18
HRX45		23
HRX55		26
HRX65		32

Laminated Contact Scraper LaCS

For locations with an adverse environment, Laminated Contact Scraper LaCS is available.

LaCS removes minute foreign material adhering to the LM rail in multiple stages and prevents it from entering the LM block with a laminated contact structure (3-layer scraper).

[Features]

- Because the three layers of scrapers fully contact the LM rail, LaCS is highly capable of removing minute foreign material.
- Low friction resistance is achieved through the use of oil-impregnated, self-lubricating synthetic foam rubber.

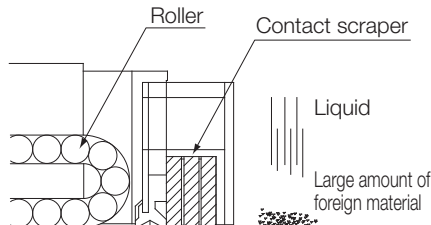

Structural Drawing

Maximum resistance value when LaCS is applied

Model No.	Sliding resistance (N)
HRX35	13
HRX45	18
HRX55	25
HRX65	34

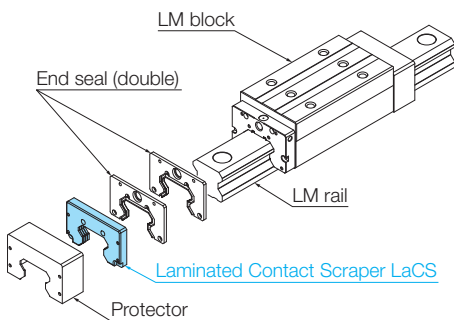

External View

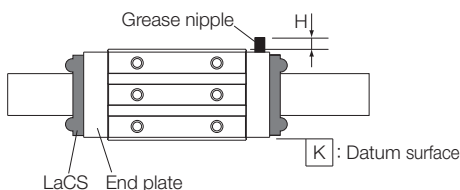

Location for mounting the side grease nipple

Symbol	Contamination protection accessories
SSHH	End seal + side seal + inner seal + LaCS
DDHH	Double seals + side seal + inner seal + LaCS
ZZHH	End seal + side seal + inner seal + LaCS + metal scraper
KKHH	Double seals + side seal + inner seal + LaCS + metal scraper
JJHH	End seals + side seals + inner seals + LaCS + protectors
TTHH	Double seal + side seals + inner seals + LaCS + protectors

Model No.	Dimensional increase with a grease nipple (mm)	
	Side greasing	
	H	Nipple type
HRX35	7.1	B-M6F
HRX45	7.1	B-PT1/8
HRX55	7.1	B-PT1/8
HRX65	6.1	B-PT1/8

Contact THK if you desire a grease nipple mounting location other than the above.

Protector

The protector minimizes the ingress of foreign material even in harsh environments where foreign material such as fine particles and liquids are present.

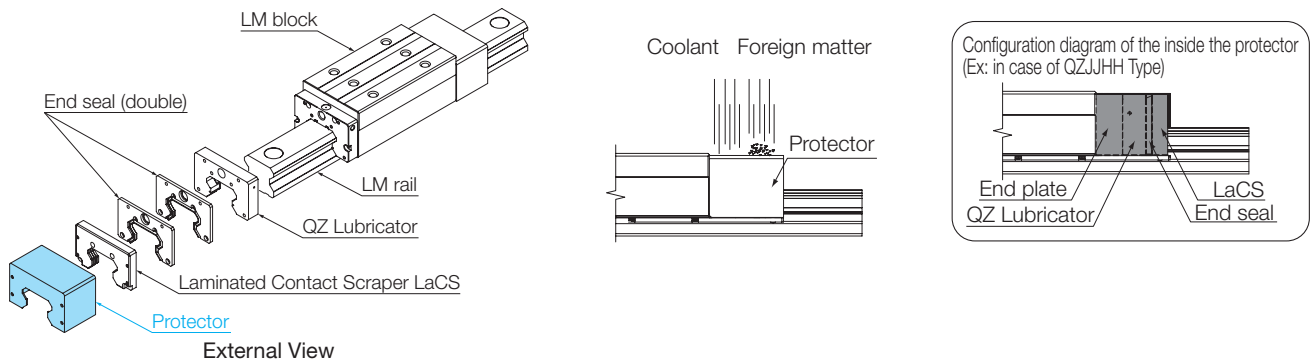

The overall LM block length with LaCS and seals attached

Unit: mm

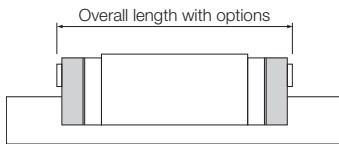

Symbol	Overall length when options are attached							
	HRX35	HRX35L	HRX45	HRX45L	HRX55	HRX55L	HRX65	HRX65L
No Symbol	116.2	144.2	143.7	178.7	173.2	222.7	231.7	296.7
UU/SS	123.2	151.2	150.7	185.7	180.2	229.7	239.1	304.1
DD	130.2	158.2	157.7	192.7	187.2	236.7	246.5	311.5
ZZ	131.6	159.6	159.9	194.9	189.4	238.9	250.3	315.3
KK	138.6	166.6	166.9	201.9	196.4	245.9	257.7	322.7
SSHH	130.2	158.2	162.7	197.7	192.2	241.7	253.7	318.7
DDHH	137.2	165.2	169.7	204.7	199.2	248.7	261.1	326.1
ZZHH	149.2	177.2	180.5	215.5	210	259.5	274.3	339.3
KKHH	156.2	184.2	187.5	222.5	217	266.5	281.7	346.7
JJHH	138.6	166.6	171.7	206.7	201.2	250.7	264.7	329.7
TTHH	145.6	173.6	178.7	213.7	208.2	257.7	272.1	337.1

Dedicated Cap for LM Rail Mounting Holes

Using dedicated caps to cover the LM rail mounting holes helps prevent foreign material from entering the mounting holes and LM block.

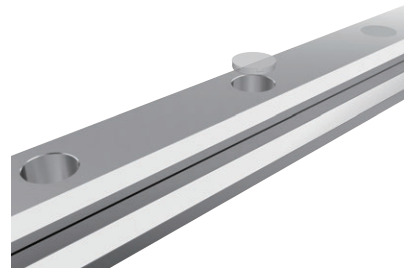

CV Cap

The caps are made of a special synthetic resin.

The CV cap is the successor to the C cap, and its new structure makes it easier to insert.



Applicable model	Cap Model No.	Used Bolts	Main dimensions (mm)	
			D	H
HRX35	CV8	M8	14.4	3.3
HRX45	CV12	M12	20.4	3.4
HRX55	CV14	M14	23.4	5.5
HRX65	CV16	M16	26.4	5.6

GC Cap

GC caps are made of metal. (They are RoHS compliant.)

GC caps adhere closer to the counterbore than CV caps, so there is no clearance once they are inserted.

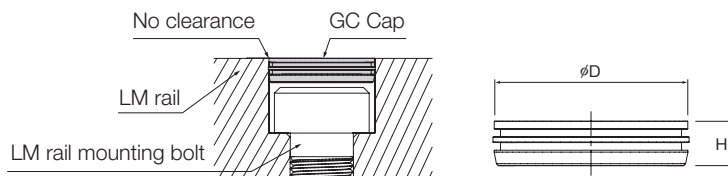

Applicable model	Cap Model No.	Used Bolts	Main dimensions (mm)	
			D	H
HRX35	GC8	M8	14.36	3.5
HRX45	GC12	M12	20.36	4.6
HRX55	GC14	M14	23.36	5.0
HRX65	GC16	M16	26.36	5.0

Note 1) GC caps are only sold with an LM Guide. They are not sold separately. The LM Guide model number code will have "GC" at the end when it is delivered.

HRX35 LC 2 UU CO + 1200L P GC _____ GC caps attached

Note 2) GC caps cannot be used with LM rails that have undergone surface treatment.

Note 3) LM rail mounting holes for GC caps are special. (The mouth is not chamfered.)

Note 4) Be careful not to injure your hand when inserting GC caps.

Note 5) Be sure to make the GC caps level with the upper surface of the LM rail and clean (wipe) that surface after insertion.

Note 6) Contact THK if this product will be used in special environments such as in a vacuum, or at very low or high temperatures.

Lubrication

Standard Grease

AFB-LF Grease is a general-purpose grease that provides excellent extreme pressure and mechanical stability properties through the use of a refined mineral oil base oil and a lithium-based consistency enhancer.

*Non-standard greases are also available. Contact THK for details.

AFB-LF Representative Physical Properties

Item	Representative physical property	Testing Method
Consistency enhancer	Lithium-based	
Base oil	Refined mineral oil	
Base oil kinematic viscosity: mm ² /s (40°C)	170	JIS K 2220 23
Worked Penetration (25°C, 60W)	275	JIS K 2220 7
Mixing stability (100,000W)	345	JIS K 2220 15
Dropping point: °C	193	JIS K 2220 8
Evaporation volume: mass% (99°C, 22h)	0.4	JIS K 2220 10
Oil separation rate: mass% (100°C, 24h)	0.6	JIS K 2220 11
Copper Plate Corrosion (B method, 100°C, 24h)	Passed	JIS K 2220 9
Low-temperature torque: mN·m (-20°C)	Starting	130
	Rotational	51
4-ball testing (welding load): N	3089	ASTM D2596
Operating temperature range: °C	-15 to 100	
Appearance Color	Yellowish brown	

QZ Lubricator

The QZ Lubricator feeds the right amount of lubricant to the LM rail raceway.

This allows an oil film to be constantly formed between the rollers and the raceway and significantly extends the lubrication maintenance interval.

The QZ Lubricator is made primarily of three components:

- (1) a highly oil-impregnated fiber net (which stores lubricant),
- (2) a high-density fiber net (which applies the lubricant to the raceways), and
- (3) an oil control plate (which adjusts the amount of oil being applied).

The lubricant is supplied from within the QZ Lubricator using the basic principle of capillary action, as used in felt-tip pens.

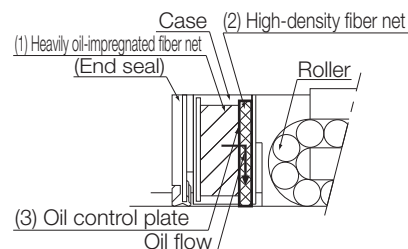

Structural Drawing

[Features]

- Since it compensates for oil loss, the lubrication maintenance interval can be significantly extended.
- It is an eco-friendly lubrication system that does not contaminate the surrounding area, as it feeds the right amount of lubricant to the roller raceway.

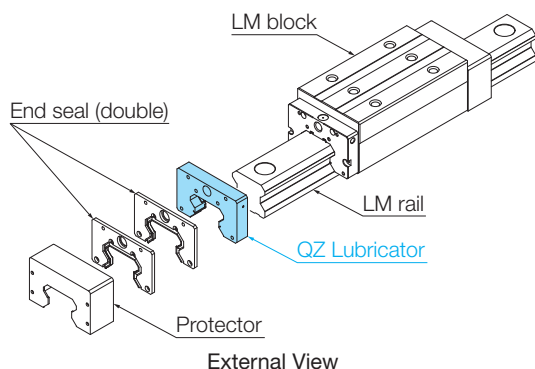

External View

Symbol	Contamination protection accessories
QZUU	End seals + QZ
QZSS	End seals + side seals + inner seals + QZ
QZDD	Double seals + side seals + inner seals + QZ
QZZZ	End seals + side seals + inner seals + metal scrapers + QZ
QZKK	Double seals + side seals + inner seals + metal scrapers + QZ
QZSSH	End seals + side seals + inner seals + LaCS + QZ
QZDDH	Double seals + side seals + inner seals + LaCS + QZ
QZZZH	End seals + side seals + inner seals + LaCS + metal scrapers + QZ
QZKHH	Double seals + side seals + inner seals + LaCS + metal scrapers + QZ
QZJHH	End seals + side seals + inner seals + LaCS + protectors + QZ
QZTTH	Double seals + side seals + inner seals + LaCS + protectors + QZ

The overall LM block length dimension with QZ Lubricator and seals attached

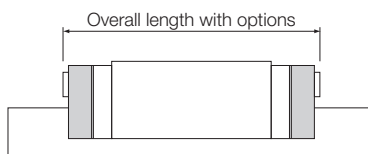

Unit: mm

Symbol	Overall length when options are attached							
	HRX35	HRX35L	HRX45	HRX45L	HRX55	HRX55L	HRX65	HRX65L
QZUU/QZSS	153.2	181.2	180.7	215.7	220.2	269.7	279.1	344.1
QZDD	160.2	188.2	187.7	222.7	227.2	276.7	286.5	351.5
QZZZ	161.6	189.6	189.9	224.9	229.4	278.9	290.3	355.3
QZKK	168.6	196.6	196.9	231.9	236.4	285.9	297.7	362.7
QZSSH	160.2	188.2	192.7	227.7	232.2	281.7	293.7	358.7
QZDDH	167.2	195.2	199.7	234.7	239.2	288.7	301.1	366.1
QZZZH	179.2	207.2	210.5	245.5	250	299.5	314.3	379.3
QZKHH	186.2	214.2	217.5	252.5	257	306.5	321.7	386.7
QZJHH	168.6	196.6	201.7	236.7	241.2	290.7	304.7	369.7
QZTTH	175.6	203.6	208.7	243.7	248.2	297.7	312.1	377.1

Radial Clearance Specifications

The Model HRX has one types of radial clearance (preload).

Medium preload (C0)

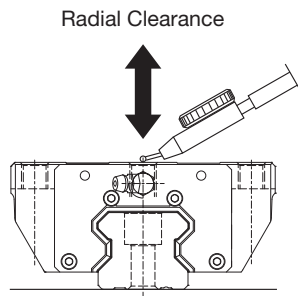

Radial Clearance Specifications Unit: μm

Applicable model	Medium preload (C0)
HRX35	-2 to -1
HRX45	-3 to -2
HRX55	-3 to -2
HRX65	-4 to -2

Accuracy Standards

The accuracy of the LM Guide is specified for each model in terms of the dimensional tolerance for height and width, the difference between height and width in a pair, and running parallelism. (High accuracy grade/Precision grade)

[Difference in Height (M)]

Indicates the difference between the minimum and maximum values of height (M) of each LM Guide used on the same plane in combination.

[Difference in Width W_2]

Indicates a difference between the minimum and maximum values of the width (W_2) between each of the LM blocks, mounted on one LM rail in combination, and the LM rail.

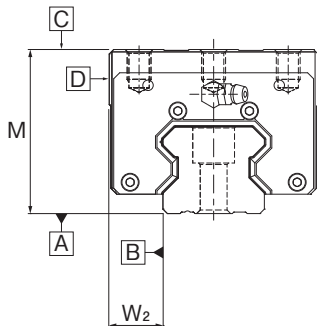

Accuracy standards Unit: mm

Model No.	Accuracy (symbol)	High accuracy grade (H)	Precision grade (P)
	Item		
35	Dimensional tolerance in height (M)	± 0.04	$\begin{matrix} 0 \\ -0.04 \end{matrix}$
	Difference in Height (M)	0.015	0.007
	Dimensional tolerance in width (W_2)	± 0.03	$\begin{matrix} 0 \\ -0.03 \end{matrix}$
	Difference in Width (W_2)	0.015	0.007
	Running parallelism of surface C against surface A	See the table below for LM rail length and running parallelism by accuracy standard	
	Running parallelism of surface D against surface B	See the table below for LM rail length and running parallelism by accuracy standard	
45 55	Dimensional tolerance in height (M)	± 0.04	$\begin{matrix} 0 \\ -0.05 \end{matrix}$
	Difference in Height (M)	0.015	0.007
	Dimensional tolerance in width (W_2)	± 0.04	$\begin{matrix} 0 \\ -0.04 \end{matrix}$
	Difference in Width (W_2)	0.015	0.007
	Running parallelism of surface C against surface A	See the table below for LM rail length and running parallelism by accuracy standard	
	Running parallelism of surface D against surface B	See the table below for LM rail length and running parallelism by accuracy standard	
65	Dimensional tolerance in height (M)	± 0.04	$\begin{matrix} 0 \\ -0.05 \end{matrix}$
	Difference in Height (M)	0.02	0.01
	Dimensional tolerance in width (W_2)	± 0.04	$\begin{matrix} 0 \\ -0.05 \end{matrix}$
	Difference in Width (W_2)	0.02	0.01
	Running parallelism of surface C against surface A	See the table below for LM rail length and running parallelism by accuracy standard	
	Running parallelism of surface D against surface B	See the table below for LM rail length and running parallelism by accuracy standard	

[Running Parallelism]

Refers to the tolerance for parallelism between the LM block and the LM rail datum surface when the LM block travels the whole length of the LM rail bolted to a reference surface.

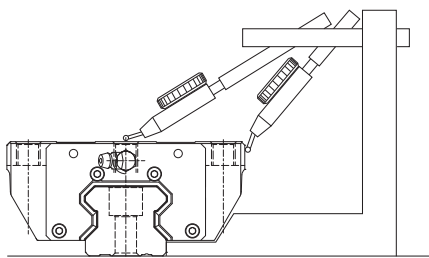

LM Rail Length and Running Parallelism by Accuracy Standard Unit: μm

Rail Length (mm)		Running parallelism values	
Above	Or less	High Accuracy Grade (H)	Precision Grade (P)
—	50	3	2
50	80	3	2
80	125	3	2
125	200	3.5	2
200	250	4	2.5
250	315	4.5	3
315	400	5	3.5
400	500	6	4.5
500	630	7	5
630	800	8.5	6
800	1000	9	6.5
1000	1250	11	7.5
1250	1600	12	8
1600	2000	13	8.5
2000	2500	14	9.5
2500	3090	16	11

Standard and Maximum Lengths of the LM Rail

The standard and maximum lengths of Model HRX LM rails are shown in the following table. If the maximum length of the desired LM rail exceeds these values, joint rails will be used. Contact THK for details.

For special rail lengths, it is recommended to use a value corresponding to the G, g dimensions from the table. As the G, g dimensions increase, this portion becomes less stable and the accuracy may be negatively affected.

*If joint rails are not allowed, and a length greater than the maximum values is required, contact THK.

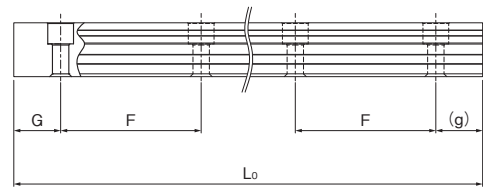

Standard Length and Maximum Length of the LM Rail

Unit: mm

Model No.	HRX35	HRX45	HRX55	HRX65
LM rail Standard length (L ₀)	280	570	780	1270
	360	675	900	1570
	440	780	1020	2020
	520	885	1140	2620
	600	990	1260	—
	680	1095	1380	—
	760	1200	1500	—
	840	1305	1620	—
	920	1410	1740	—
	1000	1515	1860	—
	1080	1620	1980	—
	1160	1725	2100	—
	1240	1830	2220	—
	1320	1935	2340	—
	1400	2040	2460	—
	1480	2145	2580	—

Model No.	HRX35	HRX45	HRX55	HRX65
LM rail Standard length (L ₀)	1560	2250	2700	—
	1640	2355	2820	—
	1720	2460	2940	—
	1800	2565	3060	—
	1880	2670	—	—
	1960	2775	—	—
	2040	2880	—	—
	2200	2985	—	—
	2360	3090	—	—
	2520	—	—	—
	2680	—	—	—
	2840	—	—	—
	3000	—	—	—
	Standard pitch	80	105	120
G, g	20	22.5	30	35
Maximum length	3000	3090	3060	3000

Shoulder Height of the Mounting Base and the Corner Radius

The mounting base for the LM rail and LM block has a reference surface on the side face to allow easy installation. The height of the datum shoulder varies based on the model. See below for details. The corner of the mounting shoulder must be machined to have a recess, or machined to be smaller than the corner radius (r), to prevent interference with the chamfer of the LM rail or the LM block. The corner radius (r) varies based on the model. See below for details.

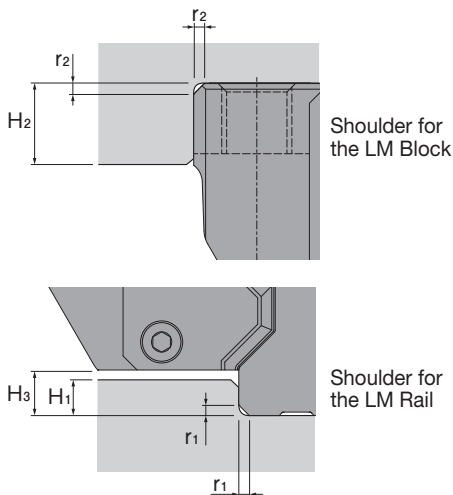

Shoulder Height of the Mounting Base and the Corner Radius

Unit: mm

Model No.	Corner radius (LM rail) r ₁ (max)	Corner radius (LM block) r ₂ (max)	Shoulder height (LM rail) H ₁ (max)	Shoulder height (LM block) H ₂ (max)	H ₃
HRX35	1.0	1.0	5.5	6.0	6.5
HRX45	1.5	1.5	6.5	8.0	8.5
HRX55	1.5	1.5	9.0	10.0	11
HRX65	1.5	2.0	9.5	10.0	12

Permissible Error in the Mounting Surface

■ Error Allowance in Parallelism Between Two Rails

Misalignment of the mounting surface can impact the product life of an LM Guide. The table below shows the approximate value (P) of the error allowance in parallelism between two rails under normal use for each model number.

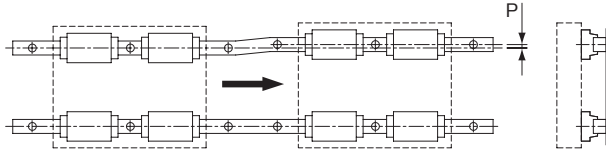

Unit: μm

Model No.	Medium preload (C0 clearance)
HRX35	9
HRX45	11
HRX55	13
HRX65	17

■ Error Allowance in Vertical Level Between Two Rails

The table below shows the value (S) of the error allowance in vertical flatness between two rails spaced 500 mm apart and compares it to the distance between the rails.

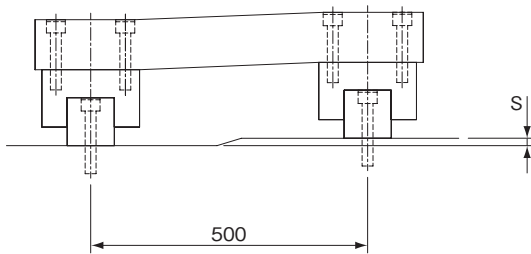

Unit: μm

Model No.	Medium preload (C0 clearance)
HRX35	70
HRX45	
HRX55	
HRX65	

■ Error Allowance in Level in the Axial Direction

The table below shows the value (Y) of the error allowance in vertical level of the block span (b), which is proportional to the block span (b).

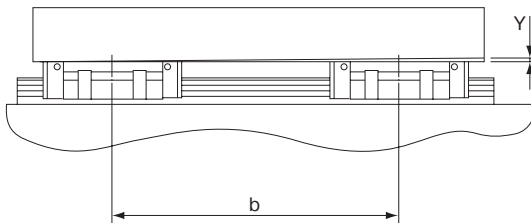

Unit: mm

Error allowance in the mounting surface (Y)	$0.000036b$
---	-------------

Specification Table

HRX-C/LC

Model Number Coding

Select an option Fixed symbol

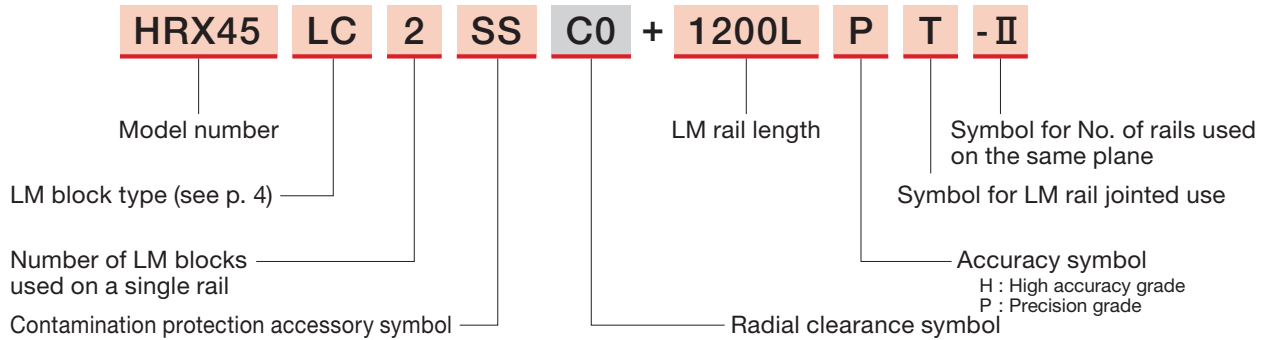

Note) Please contact THK if you wish to order LM rails and LM blocks separately.

Model No.	External dimensions							Block dimensions										Pilot hole for side nipple			Greasing hole on the top face			
	M	W	L	B	C	C ₂	S	H	L ₁	T	T ₁	K	N	E	Grease Nipple	e ₀	f ₀	D ₀	D ₂ (O-ring)	V	e ₁	d ₂		
HRX35	C	48	100	123.2	82	62	52	M10 through	8.5	92.2	12	10	41.5	8	12	B-M6F	7.2	9.5	5.2	10.2	0.45	5.8	1	
	LC	48	100	151.2	82	62	52	M10 through	8.5	120.2	12	10	41.5	8	12	B-M6F	7.2	9.5	5.2	10.2	0.45	5.8	1	
HRX45	C	60	120	150.7	100	80	60	M12 through	10.5	115.7	17.3	15	51.5	8.75	16	B-PT1/8	7.5	7.75	5.2	10.2	0.45	6.9	1	
	LC	60	120	185.7	100	80	60	M12 through	10.5	150.7	17.3	15	51.5	8.75	16	B-PT1/8	7.5	7.75	5.2	10.2	0.45	6.9	1	
HRX55	C	70	140	180.2	116	95	70	M14 through	12.5	143.2	18.2	18	59	11.2	16	B-PT1/8	6.8	9.3	5.2	10.2	0.45	6.8	1	
	LC	70	140	229.7	116	95	70	M14 through	12.5	192.7	18.2	18	59	11.2	16	B-PT1/8	6.8	9.3	5.2	10.2	0.45	6.8	1	
HRX65	C	90	170	239.1	142	110	82	M16 through	14.5	195.7	22.3	20	78	18	16	B-PT1/8	8.65	16.6	5.2	10.2	0.45	8.65	1	
	LC	90	170	304.1	142	110	82	M16 through	14.5	260.7	22.3	20	78	18	16	B-PT1/8	8.65	16.6	5.2	10.2	0.45	8.65	1	

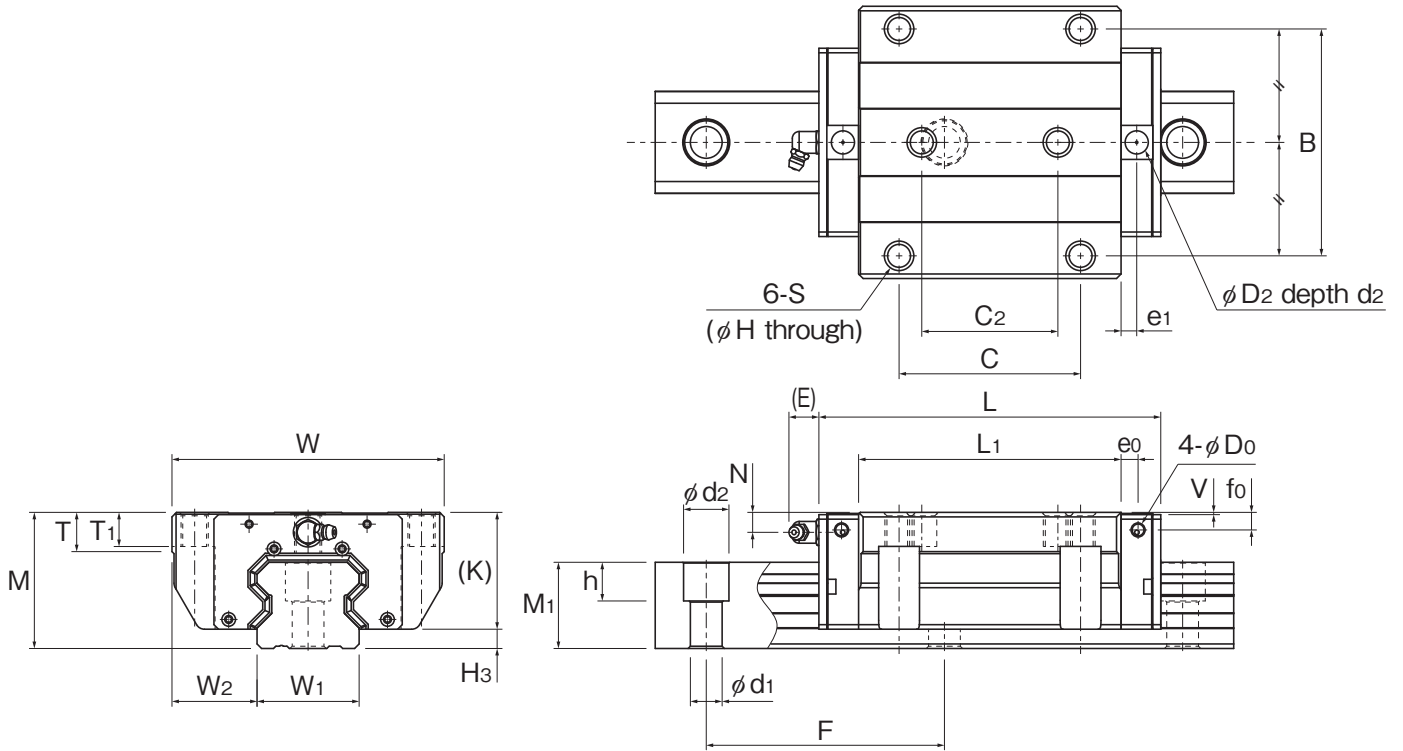

Unit: mm

H ₃	Rail dimensions					Basic load rating (kN)			Static permissible moment (kN·m)*				Mass	
	W ₁ 0 -0.05	W ₂	M ₁	F	d ₁ ×d ₂ ×h	C ₁₀₀	C ₀	M _A		M _B		M _C	LM block (kg)	LM rail (kg/m)
								1 block	Double blocks	1 block	Double blocks			
6.5	34	33	29	80	9×14×12	56.0	150.1	2.33	11.59	2.33	11.59	1.81	1.93	6.33
6.5	34	33	29	80	9×14×12	68.9	195.7	3.92	18.60	3.92	18.60	2.36	2.55	6.33
8.5	45	37.5	38	105	14×20×17	94.3	250.4	4.85	23.90	4.85	23.90	3.84	3.51	10.9
8.5	45	37.5	38	105	14×20×17	116.0	326.7	8.17	38.44	8.17	38.44	5.01	4.64	10.9
11	53	43.5	44	120	16×23×20	134.5	369.9	8.86	42.34	8.86	42.34	6.86	5.85	15.6
11	53	43.5	44	120	16×23×20	169.5	497.9	15.86	72.70	15.86	72.70	9.24	7.96	15.6
12	63	53.5	53	150	18×26×22	205.5	567.0	18.43	86.49	18.43	86.49	12.27	13.34	22.6
12	63	53.5	53	150	18×26×22	257.0	756.0	32.04	146.69	32.04	146.69	16.35	17.94	22.6

*Static permissible moment 1 block: static permissible moment value with 1 LM block
 Double blocks: static permissible moment value with 2 blocks closely contacting with each other

Specification Table

HRX-R/LR

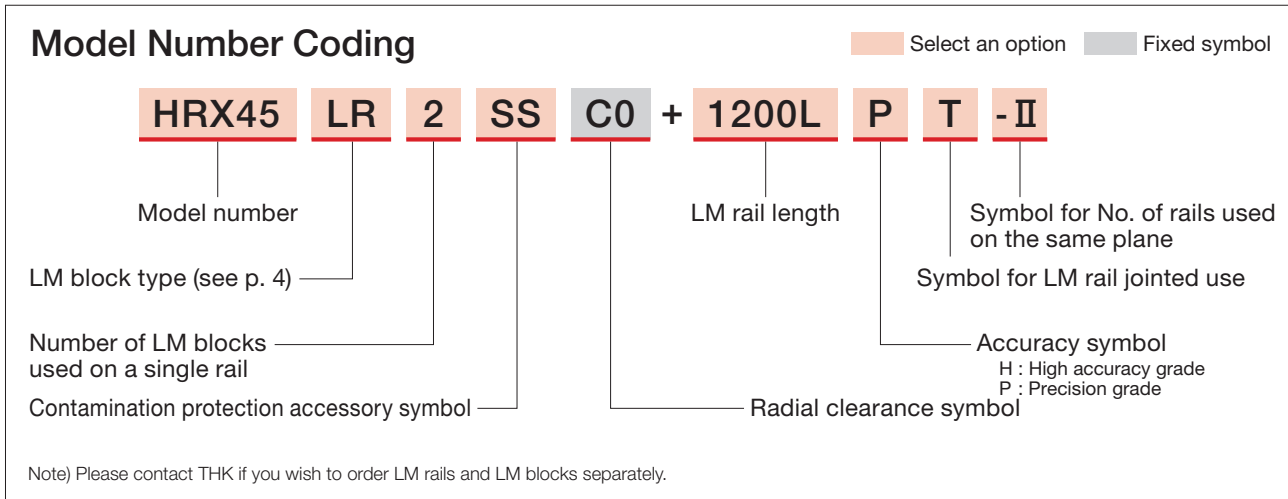

Model No.		External dimensions			Block dimensions								Pilot hole for side nipple			Greasing hole on the top face				
		M	W	L	B	C	S×ℓ	L ₁	T	K	N	E	Grease Nipple	e ₀	f ₀	D ₀	D ₂ (O-ring)	V	e ₁	d ₂
HRX35	R	55	70	123.2	50	50	M8×10	92.2	18.5	48.5	15	12	B-M6F	7.2	16.5	5.2	10.2	7.45	5.8	1
	LR	55	70	151.2	50	72	M8×10	120.2	18.5	48.5	15	12	B-M6F	7.2	16.5	5.2	10.2	7.45	5.8	1
HRX45	R	70	86	150.7	60	60	M10×12.5	115.7	24.5	61.5	18.75	16	B-PT1/8	7.5	17.75	5.2	10.2	10.45	6.9	1
	LR	70	86	185.7	60	80	M10×12.5	150.7	24.5	61.5	18.75	16	B-PT1/8	7.5	17.75	5.2	10.2	10.45	6.9	1
HRX55	R	80	100	180.2	75	75	M12×15	143.2	27.5	69	21.2	16	B-PT1/8	6.8	19.3	5.2	10.2	10.45	6.8	1
	LR	80	100	229.7	75	95	M12×15	192.7	27.5	69	21.2	16	B-PT1/8	6.8	19.3	5.2	10.2	10.45	6.8	1
HRX65	R	100	126	239.1	76	70	M16×20	195.7	29.5	88	28	16	B-PT1/8	8.65	26.6	5.2	10.2	10.45	8.65	1
	LR	100	126	304.1	76	120	M16×20	260.7	29.5	88	28	16	B-PT1/8	8.65	26.6	5.2	10.2	10.45	8.65	1

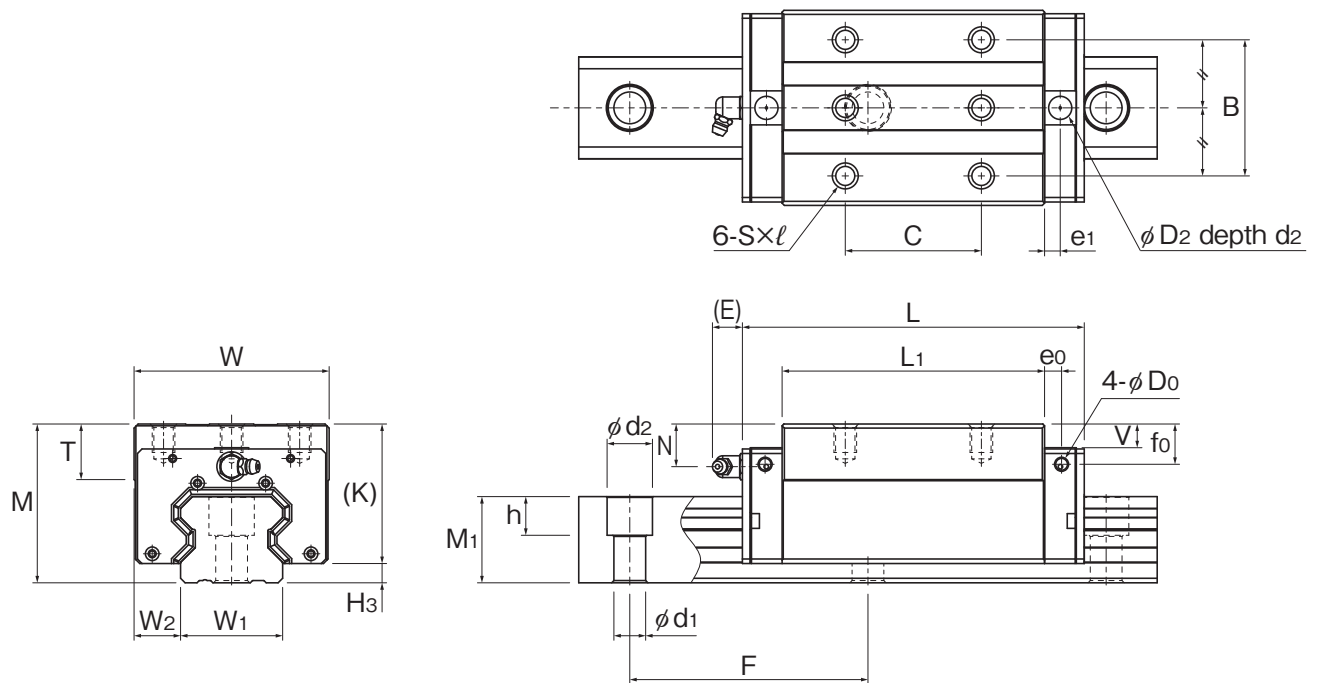

Unit: mm

H ₃	Rail dimensions					Basic load rating (kN)			Static permissible moment (kN·m)*				Mass	
	W ₁ 0 -0.05	W ₂	M ₁	F	d ₁ ×d ₂ ×h	C ₁₀₀	C ₀	M _A		M _B		M _C	LM block (kg)	LM rail (kg/m)
								1 block	Double blocks	1 block	Double blocks			
6.5	34	18	29	80	9×14×12	56.0	150.1	2.33	11.59	2.33	11.59	1.81	1.73	6.33
6.5	34	18	29	80	9×14×12	68.9	195.7	3.92	18.60	3.92	18.60	2.36	2.23	6.33
8.5	45	20.5	38	105	14×20×17	94.3	250.4	4.85	23.90	4.85	23.90	3.84	3.20	10.9
8.5	45	20.5	38	105	14×20×17	116.0	326.7	8.17	38.44	8.17	38.44	5.01	4.15	10.9
11	53	23.5	44	120	16×23×20	134.5	369.9	8.86	42.34	8.86	42.34	6.86	5.31	15.6
11	53	23.5	44	120	16×23×20	169.5	497.9	15.86	72.70	15.86	72.70	9.24	7.12	15.6
12	63	31.5	53	150	18×26×22	205.5	567.0	18.43	86.49	18.43	86.49	12.27	12.06	22.6
12	63	31.5	53	150	18×26×22	257.0	756.0	32.04	146.69	32.04	146.69	16.35	16.01	22.6

*Static permissible moment 1 block: static permissible moment value with 1 LM block
 Double blocks: static permissible moment value with 2 blocks closely contacting with each other

Feature 3 LM Blocks and LM Rails Available for Individual Sale

HRX-GK

LM blocks and LM rails available for individual sale

Flexible combinations, simple, quick

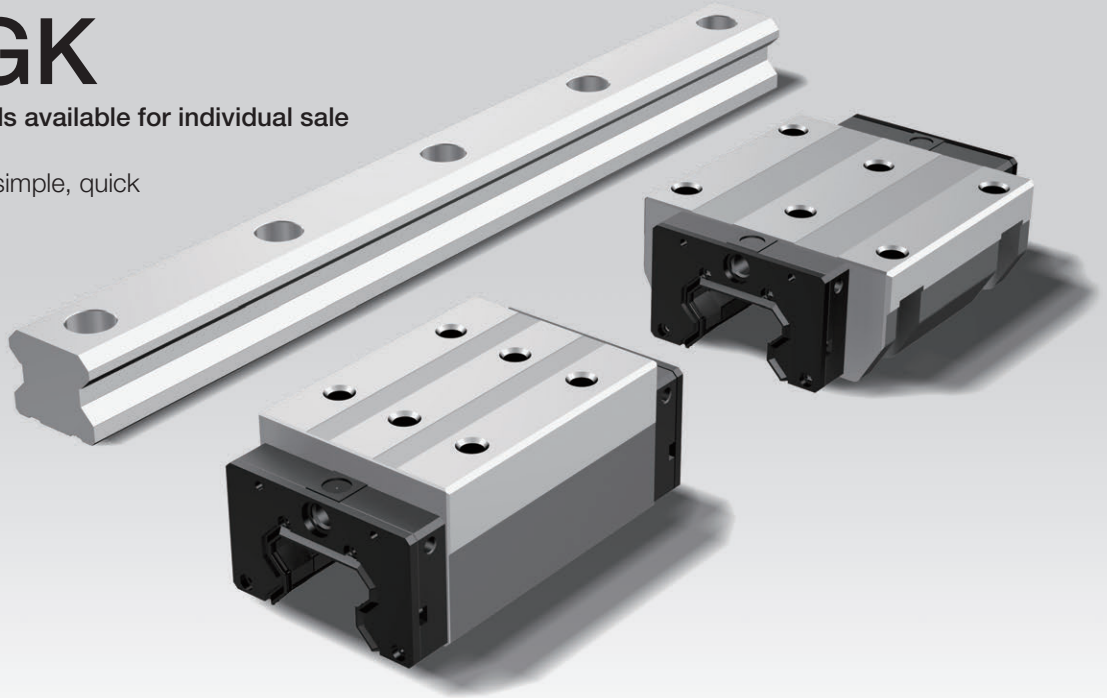

Lineup

Block Type		HRX35	HRX45	HRX55	HRX65
Standard type	R	○	○	○	○
	C	○	○	○	○
Long type	LR	○	○	○	○
	LC	○	○	○	○

Model Number Coding

LM rail

HRX45 - **3000L** **H** **(GK) RAIL**

Model number

LM rail length

GK series
LM rail symbol

Accuracy symbol

H : High accuracy grade
P : Precision grade

Note 1) For LM rails and LM blocks, (GK) is used only for HRX35 and HRX45.

Note 2) For LM rails, (GK) is used only for dimensions in the table to the right.

 Select an option Fixed symbol

LM block

HRX45 **LR** **1** **SS** **C0** **H** **(GK) BLOCK**

Model number

LM block type

Number of LM blocks
(1 only)

Contamination protection
accessory symbol (SS only)

GK series
LM block symbol

Accuracy symbol

H : High accuracy grade
P : Precision grade

Radial clearance symbol

Accuracy Standards

The accuracy of the LM Guide is specified for each model in terms of the dimensional tolerance for height and width, the difference between height and width in a pair, and running parallelism. (High accuracy grade/Precision grade)

[Difference in Height (M)]

Indicates the difference between the minimum and maximum values of height (M) of each LM Guide used on the same plane in combination.

[Difference in Width W₂]

Indicates a difference between the minimum and maximum values of the width (W₂) between each of the LM blocks, mounted on one LM rail in combination, and the LM rail.

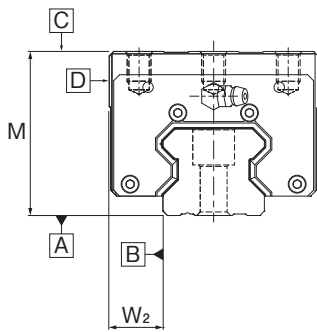

Accuracy standards

Unit: mm

Model No.	Accuracy (symbol)		High accuracy grade (H)	Precision grade (P)
	Item			
35	Dimensional tolerance in height (M)		±0.04	0 -0.04
	Height M Difference in dimension	Multiple blocks on a single rail (1 set)	0.015	0.007
		Multiple blocks on multiple rails (Multiple sets)	0.030	0.025
	Dimensional tolerance in width (W ₂)		±0.03	0 -0.03
	Difference in Width W ₂		0.015	0.007
	Running parallelism of surface C against surface A		See the table on p. 8 for LM rail length and running parallelism by accuracy standard.	
	Running parallelism of surface D against surface B		See the table on p. 8 for LM rail length and running parallelism by accuracy standard.	
45 55	Dimensional tolerance in height (M)		±0.04	0 -0.05
	Height M Difference in dimension	Multiple blocks on a single rail (1 set)	0.015	0.007
		Multiple blocks on multiple rails (Multiple sets)	0.030	0.025
	Dimensional tolerance in width (W ₂)		±0.04	0 -0.04
	Difference in Width W ₂		0.015	0.007
	Running parallelism of surface C against surface A		See the table on p. 8 for LM rail length and running parallelism by accuracy standard.	
	Running parallelism of surface D against surface B		See the table on p. 8 for LM rail length and running parallelism by accuracy standard.	
65	Dimensional tolerance in height (M)		±0.04	0 -0.05
	Height M Difference in dimension	Multiple blocks on a single rail (1 set)	0.02	0.010
		Multiple blocks on multiple rails (Multiple sets)	0.035	0.025
	Dimensional tolerance in width (W ₂)		±0.04	0 -0.05
	Difference in Width W ₂		0.020	0.010
	Running parallelism of surface C against surface A		See the table on p. 8 for LM rail length and running parallelism by accuracy standard.	
	Running parallelism of surface D against surface B		See the table on p. 8 for LM rail length and running parallelism by accuracy standard.	

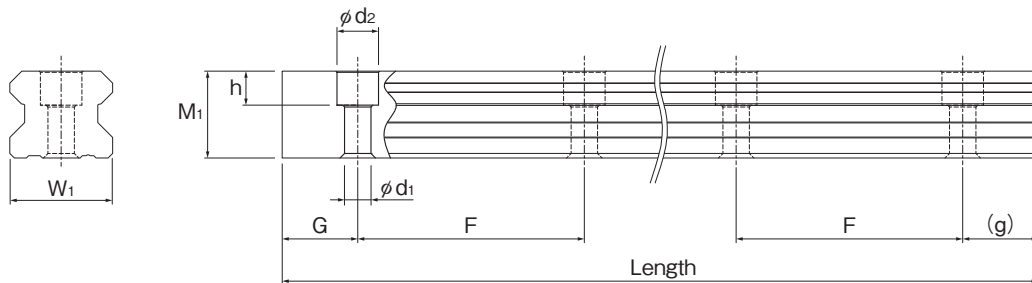

LM rail dimensions

Unit: mm

Model No.	Rail dimensions					Mass
	W ₁	M ₁	F	d ₁ ×d ₂ ×h	Length (G,g)	LM rail (kg/m)
HRX35	34	29	80	9×14×12	3000 (20,20)	6.33
HRX45	45	38	105	14×20×17	3000 (20,40)	10.9
HRX55	53	43.5	120	16×23×20	3000 (20,40)	15.6
HRX65	63	53.5	150	18×26×22	3000 (20,40)	22.6

HRX, HRX(GK) Calculating the static safety factor and nominal life

Static Safety Factor

To calculate a load applied to the LM Guide, you must first obtain the average load required to determine the service life and the maximum load needed to determine the static safety factor. In particular, if the system starts and stops frequently, if a cutting load acts on the system, or if a large moment or torque caused by an overhanging load is applied, it may experience an unexpectedly large load. When selecting a model number, make sure that the desired model is capable of supporting the required maximum load (whether stationary or in motion).

The reference values for the static safety factor are shown in the table to the right.

Reference Values for the Static Safety Factor (f_s)

Machine	Load conditions	Lower limit of f_s
General industrial machinery	Without vibration or impacts	3.0 to 6.0
	With vibration or impact	4.0 to 7.0
Machine tools	Without vibration or impacts	3.0 to 6.0
	With vibration or impact	6.0 to 10.0

*The standard value of the static safety factor may vary depending on usage conditions such as the environment, lubrication status, mounting accuracy, and/or rigidity.

$$f_s = \frac{C_0}{P_{\max}} \dots\dots (1)$$

f_s : Static safety factor
 C_0 : Basic static load rating (N)
 P_{\max} : Maximum applied load (N)

Service Life

Nominal Life

The nominal life (L) means the total travel distance that 90% of a group of units can achieve without flaking (scale-like pieces on the metal surface peeling off) after individually running under the same conditions. The nominal life of Model HRX is obtained using equation (2).

$$L = \left(\frac{f_H \cdot f_T \cdot f_C}{f_W} \cdot \frac{C}{P_C} \right)^{\frac{10}{3}} \times 100 \dots\dots (2)$$

*The basic dynamic load rating (C) indicates the load for which the nominal life (L) is 100 km when a group of identical LM Guide units independently operate under that load when it is applied with a constant direction and magnitude.

L : Nominal life (km)
 C : Basic dynamic load rating (N)
 P_C : Calculated load (N)
 f_H : Hardness factor (See the general catalog for details)
 f_T : Temperature factor (See the general catalog for details)
 f_C : Contact factor (See the general catalog for details)
 f_W : Load factor (See the general catalog for details)

Service Life in Hours

Once the nominal life (L) has been obtained, the service life in hours can be obtained using equation (3) if the stroke length and the number of cycles are constant.

$$L_h = \frac{L \times 10^6}{2 \times \ell_s \times n_1 \times 60} \dots\dots (3)$$

L_h : Service life in hours (h)
 ℓ_s : Stroke length (mm)
 n_1 : Cycles per minute (min^{-1})

Handling

- (1) Please use at least two people to move any product weighing 20 kg or more, or use a dolly or another conveyance. Otherwise, it may cause injury or damage the unit.
- (2) Do not disassemble the parts. This will result in loss of functionality.
- (3) Tilting an LM block or LM rail may cause them to fall by their own weight.
- (4) Take care not to drop or strike the LM guide. Otherwise, it may cause injury or damage the unit. Even if there is no outward indication of damage, a sudden impact could prevent the unit from functioning properly.
- (5) When installing the LM Guide, be sure not to remove the LM block from the LM rail.
- (6) Placing a hand inside the LM rail mounting hole may lead to the hand being caught between the block and rail and cause injury.
- (7) Wear appropriate safety gear, such as protective gloves and safety shoes, when handling the product.

Precautions on Use

- (1) Prevent foreign materials, such as cutting chips or coolant, from entering the product. Failure to do so could damage the product.
- (2) Prevent foreign materials, such as cutting chips, coolant, corrosive solvents or water from getting in the product by using a bellows or cover when the product is used in an environment where such a thing is likely.
- (3) Do not use this product if the external temperature exceeds 80° C. If used in excess of this temperature, there is a risk that the resin and rubber parts may deform or become damaged (except the heat-resistant type).
- (4) If foreign materials such as cutting chips adhere to the product, replenish the lubricant after washing the product.
- (5) Very small strokes can inhibit the formation of an oil film between the raceways and the area of contact for the rollers, resulting in fretting. Therefore, be sure to use a type of grease with high fretting resistance properties if the stroke will be small. We recommend periodically allowing the LM block to stroke a distance roughly equal to its length to help ensure that a film forms between the raceways and rollers.
- (6) Do not forcibly drive a pin, key, or other positioning device into the product. This could create indentations on the rolling surface and impair the product's function.
- (7) If the operation requires the block to be removed, please use a removing/mounting jig. (The removing/mounting jig is not provided as standard. To obtain one, please contact THK.)
- (8) When using a removing/mounting jig, align the ends of the LM rail and the jig and mount the block when the jig and rail are in parallel.
- (9) Mounting the block while it is tilted can lead to contamination by foreign materials, damage to internal components, or dropped rollers.
- (10) Inserting and using the LM block on the LM rail while rollers are missing could lead to premature failure of the product.
- (11) If any balls fall out of the LM block, contact THK. Do not use the product in that condition.
- (12) If the LM Guide breaks due to an accident or other cause, the block may get dislodged from the rail and fall. For the safe use of these products, take precautions such as adding a mechanism to prevent blocks from falling.
- (13) If the mounting material lacks sufficient rigidity or accuracy, the bearing load may be focused in one area, and bearing functionality will dramatically decrease. Therefore, carefully consider the rigidity and accuracy of the housing and base, and the strength of the securing bolts.
- (14) If you will be removing the LM block from the LM rail and then replacing the block, an LM block mounting/removing jig that facilitates such installation is available. Contact THK for details.

Lubrication

- (1) Thoroughly wipe off anti-rust oil and feed lubricant before using the product.
- (2) Do not mix different lubricants. Even grease containing the same type of thickening agent may, if mixed, interact in an adverse manner due to disparate additives or other ingredients.
- (3) When using the product in locations exposed to constant vibrations or in special environments such as in clean rooms, vacuums, and low/high temperatures, use a lubricant suitable for its use/environment.
- (4) When lubricating products that do not feature a grease nipple or oil hole, directly coat the raceways with lubricant and perform several warm-up strokes to ensure that the grease permeates the interior.
- (5) Grease viscosity can vary depending on the temperature. Please keep in mind that the LM Guide's sliding resistance may be affected by changes in viscosity.
- (6) After lubrication, sliding resistance of the LM Guide may increase due to the stirring resistance of the grease. Be sure to perform a warm-up operation and allow the grease to break in sufficiently before operating the machinery.
- (7) Excess grease may spatter after lubrication. Wipe off spattered grease as necessary.
- (8) Grease deteriorates over time, which decreases the lubricity, so perform regular grease inspections and replenish grease based on frequency of use.
- (9) How often grease should be replenished varies depending on the usage conditions and environment. We recommend greasing the system approximately every 100 km traveled (3 to 6 months). Final greasing interval/amount should be set at an actual machine.
- (10) The lubricant may not reach the raceway if the LM Guide is not installed in a horizontal orientation.
- (11) When adopting oil lubrication, the lubricant may not be distributed throughout the LM system depending on the mounting orientation of the LM block. Contact THK for details.

Storage

When storing the LM Guide, pack it as designated by THK and store it indoors in a horizontal position away from high or low temperatures and high humidity.

Please note that if the product has been kept in storage for an extended period, the lubricant inside may have deteriorated. Please ensure that you replenish the lubricant before using.

Disposal

The product should be treated as industrial waste and disposed of appropriately.

Recommended Products

Caged Roller LM Guide

SRG

- Ultra-high Rigidity
- Global Standard Size
- Wide Array of Options
- Long-term maintenance-free operation

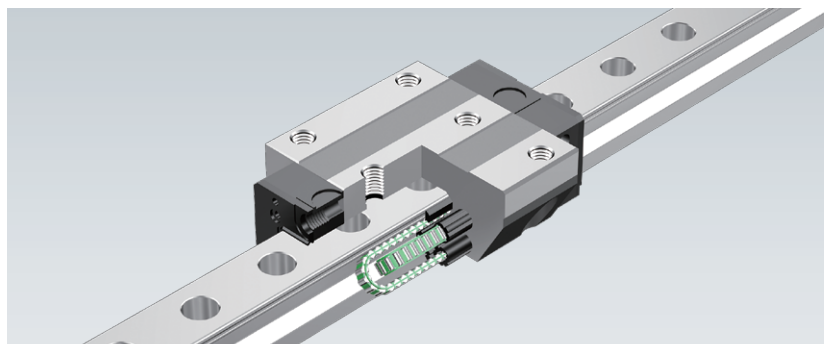

Caged Roller LM Guide

SRN

- Ultra-high Rigidity
- Thin, low center of gravity type with lower product height than the SRG
- Long-term maintenance-free operation

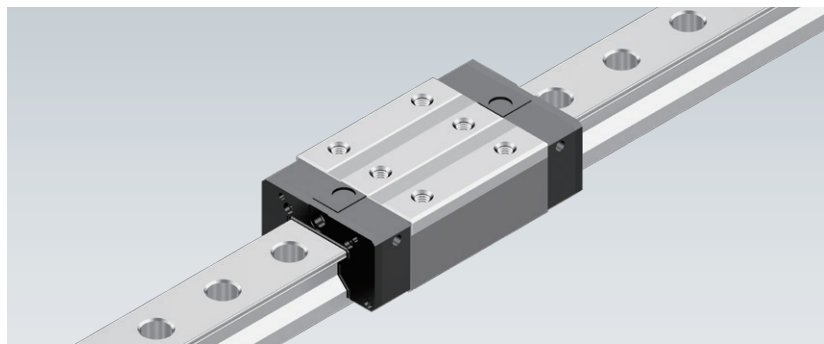

4-Way Equal Load Roller-Type LM Guide HRX

●“LM Guide” and “” are registered trademarks of THK CO., LTD.

- The actual products may differ from the pictures and photographs in this catalog.
- Outward appearances and specifications are subject to change without notice for the purpose of improvement. Please consult with THK before using.
- Although great care has been taken in the production of this catalog, THK will not take any responsibility for damage resulting from typographical errors or omissions.
- For exports of our products and technologies and sales for export, our basic policy is to comply with the Foreign Exchange and Foreign Trade Act and other laws and regulations. Please consult us in advance if you want to export our products by the piece.

All rights reserved

THK CO., LTD.

Headquarters 2-12-10 Shibaura, Minato-ku, Tokyo 108-8506 Japan

International Sales Department Phone: +81-3-5730-3860

www.thk.com

North America

THK America, Inc.

- Headquarters.....Phone: +1-847-310-1111
- Chicago OfficePhone: +1-847-310-1111
- North East Office.....Phone: +1-631-244-1565
- Atlanta Office.....Phone: +1-770-840-7990
- Los Angeles OfficePhone: +1-949-955-3145
- San Francisco Office.....Phone: +1-925-455-8948
- Detroit Office.....Phone: +1-248-858-9330
- Toronto OfficePhone: +1-905-820-7800

South America

THK BRAZIL INDUSTRIA E COMERCIO LTDA.

Phone: +55-11-3767-0100

Europe

THK GmbH

- European Headquarters.....Phone: +49-2102-7425-555
- Düsseldorf OfficePhone: +49-2102-7425-0
- Stuttgart Office.....Phone: +49-7141-4988-500
- U.K. Office.....Phone: +44-1384-471550
- Italy OfficePhone: +39-02-9901-1801

- Sweden Office.....Phone: +46-8-445-7630
- Austria Office.....Phone: +43-7229-51400
- Spain Office.....Phone: +34-93-652-5740
- Turkey OfficePhone: +90-216-362-4050
- Prague OfficePhone: +420-2-41025-100
- Moscow Office.....Phone: +7-495-649-80-47
- THK Europe B.V.
- Eindhoven Office.....Phone: +31-40-290-9500
- THK France S.A.S.
- Paris Office.....Phone: +33-1-7425-3800

China

THK (CHINA) CO., LTD.

- HeadquartersPhone: +86-411-8733-7111
- Shanghai Branch.....Phone: +86-21-6219-3000
- Beijing Branch.....Phone: +86-10-8441-7277
- Chengdu BranchPhone: +86-28-8526-8025
- Guangzhou BranchPhone: +86-20-8523-8418
- Shenzhen Branch.....Phone: +86-755-2642-9587
- Xian Branch.....Phone: +86-29-8834-1712
- THK (SHANGHAI) CO., LTD.Phone: +86-21-6275-5280

Taiwan

THK TAIWAN CO., LTD.

- Taipei Headquarters.....Phone: +886-2-2888-3818
- Taichung Office.....Phone: +886-4-2359-1505
- Tainan OfficePhone: +886-6-289-7668

South Korea

- Seoul Representative Office.....Phone: +82-2-3468-4351

Singapore

THK LM System Pte. Ltd.....Phone: +65-6884-5500

Thailand

THK RHYTHM (THAILAND) CO., LTD. LM System Division

- Bangkok Branch.....Phone: +66-2751-3001

India

THK India Pvt. Ltd.

- Headquarters & Bengaluru Branch.....Phone: +91-80-2340-9934
- Pune Branch.....Phone: +91-72-7600-2071
- Chennai Branch.....Phone: +91-44-4042-3132
- Ahmedabad BranchPhone: +91-79-6134-4925
- Delhi Branch.....Phone: +91-12-4676-8695